



# Automation Systems AUSTRALIA

## VIPER 4 / VIPER 5

24 Volt Telescopic Linear Actuator System  
with Adjustable Limit Stops



### **Important!**

Please read the manual carefully as it contains important points that need to be followed for a successful installation, we recommend reading all the preliminary information FIRST (page 1-3) then proceed to the relevant installation section and read in its entirety at least once before beginning the installation.

Pull To Open Installation (Gate opens TOWARDS the motor) begins Page 4

Push To Open Installation (Gate opens AWAY from the motor) begins Page 7

## Specifications

Voltage	24V DC
Stroke	2A
-424	400/370/340mm No Limit Stops/One Limit Stop/Two Limit Stops
-524	500/470/440mm No Limit Stops/One Limit Stop/Two Limit Stops
Current	2000N
Thrust	Transfer Gear
Gearing Structure	Aluminium Extrusion
Case Material	Stainless Steel with Die-Cast Alloy End Adapter
Piston Material	Limit Stop (Open and Closed)
Limit Type	90%
Duty Cycle	-20°C to 60°C
Working Temperature	IP 55
IP Rating	

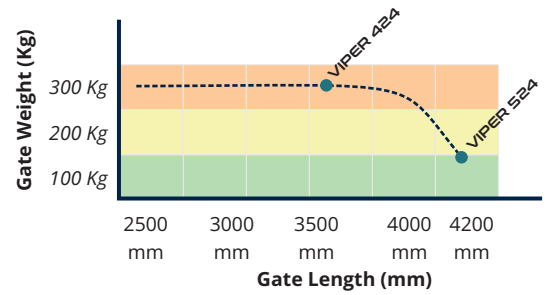

\*Tested ratings are based on ball bearing hinges and no wind resistance

## Dimensions

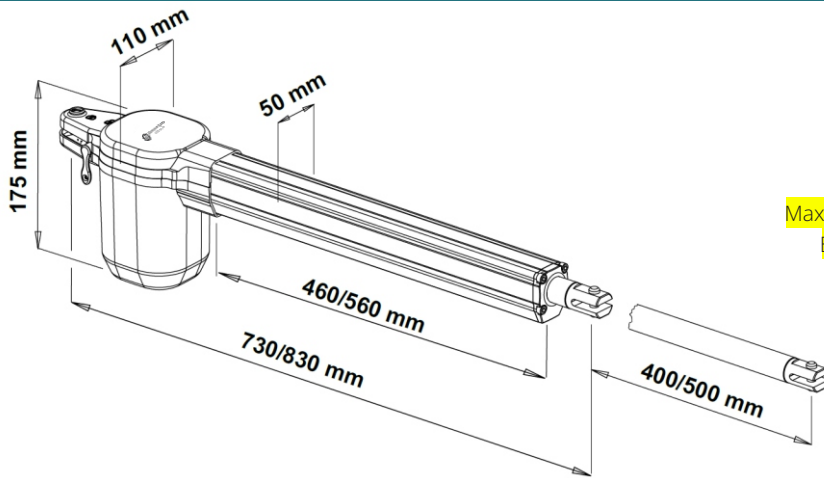

Max. Stroke Length is without the use of the limit stops  
Each limit stop reduces 30mm of usable stroke.

Viper 424 with both Limit Stops 340  
Viper 424 with both Limit Stops 440

## Manual Release/Clutch

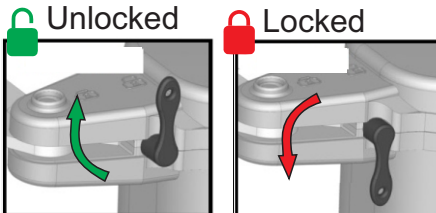

### To Unlock:

insert the triangle key lever into the override slot with lever facing DOWN.  
Turn the key 180° to lock.

### To Lock:

insert the triangle key lever into the override slot with lever facing UP.  
Turn the key 180° to lock.

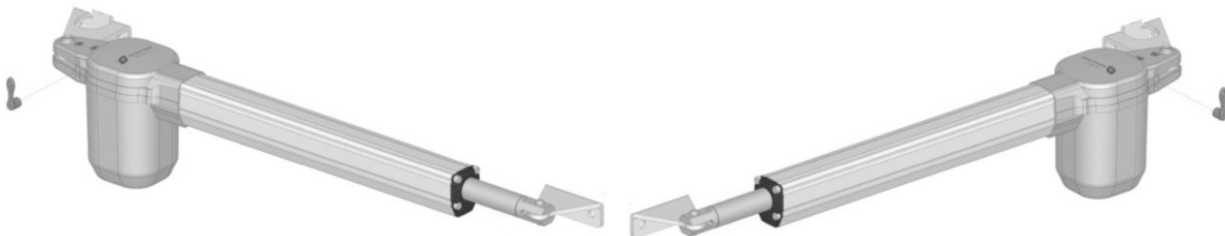

## Installers Brief Checklist

- Ensure the gate(s) structure is rigid and does not flex
- Ensure you will be using an adequate fastening system to suit the structure and environment
- Ensure the gate(s) move freely and uniformly
- Ensure that the installation geometry can be adhered to
- Ensure that if any underground work is occurring you have followed the local regulations and checked with utilities providers
- Ensure the correct operator is to be installed based on size, weight, geometry and wind resistance
- Never supply mains power to a gate motor directly
- Never install if it will present a hazard or danger

## Actuator Placement

The actuator requires a minimum of 200mm between the ground and the centre horizontal gate rail for the mounting, if no additional rail has been factored a 6mm riser plate has been supplied can be utilised to create a mounting point on the gate. Examples are seen below.

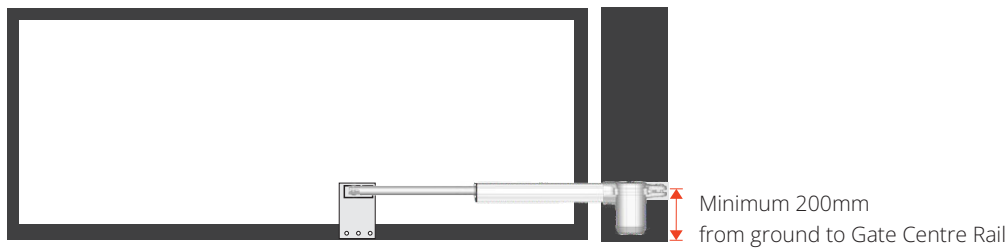
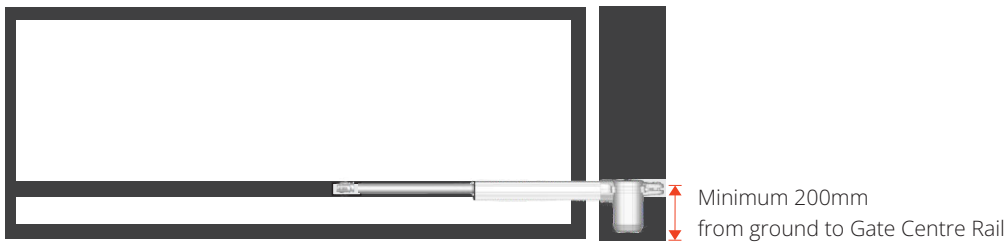

## Extending Narrow Posts (Pull To Open)

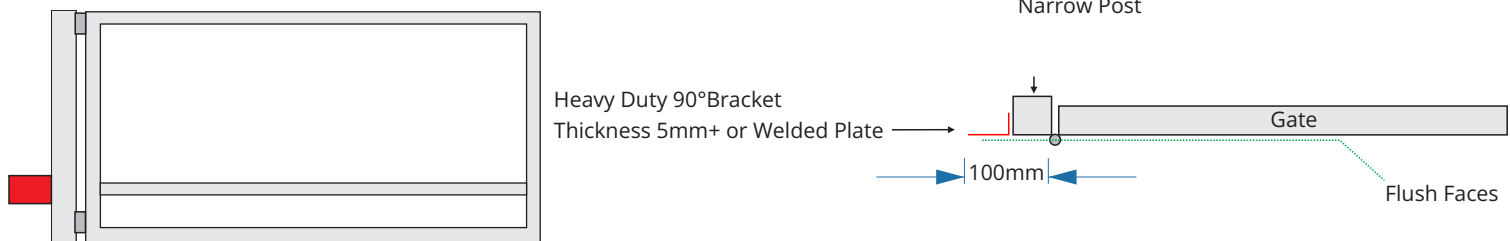

## Push to Open Installation Corrections to Achieve Y

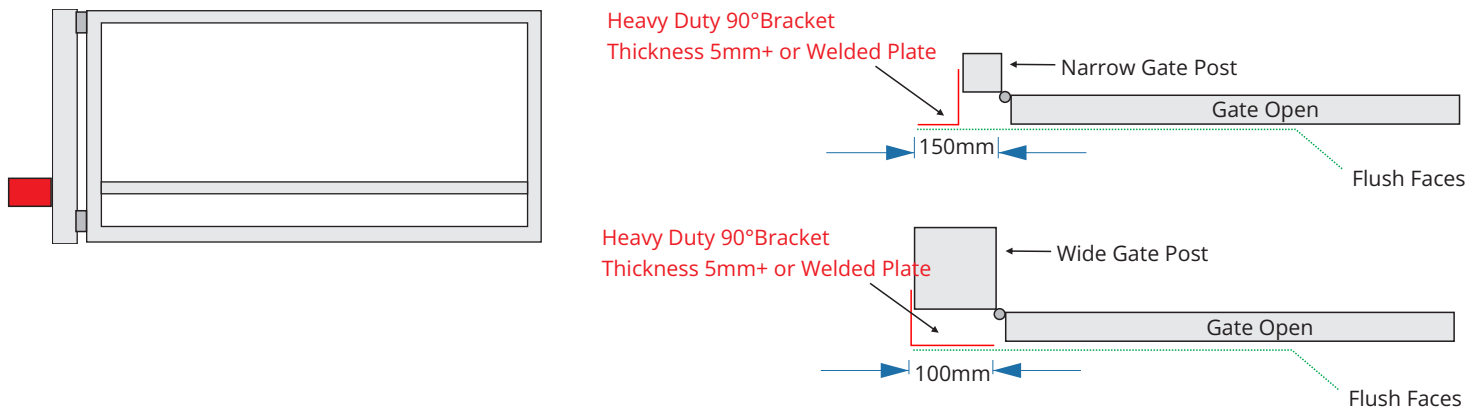

When a gate post is too narrow for automation an extension plate/bracket to widen the mounting area will be required.

## Gate Bracket

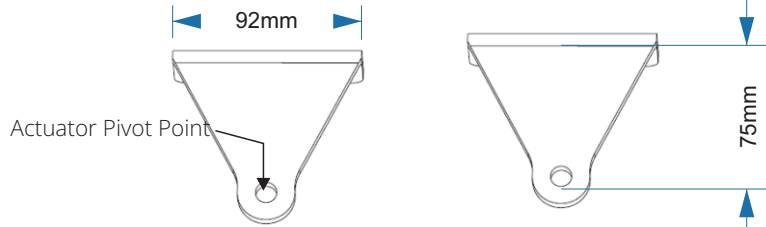
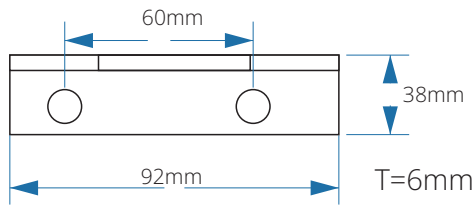

## Riser plate

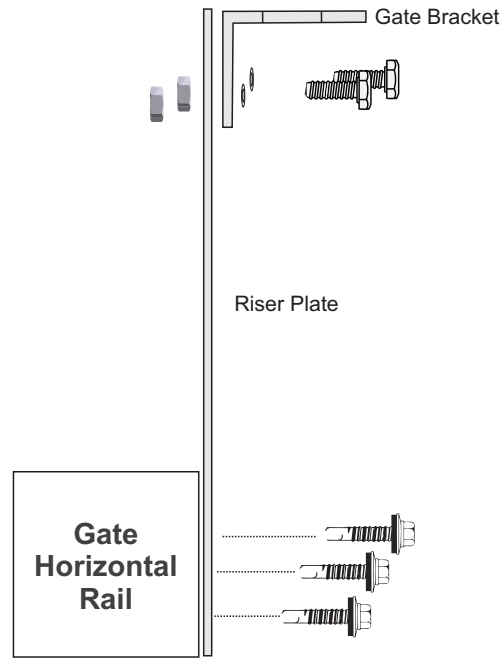
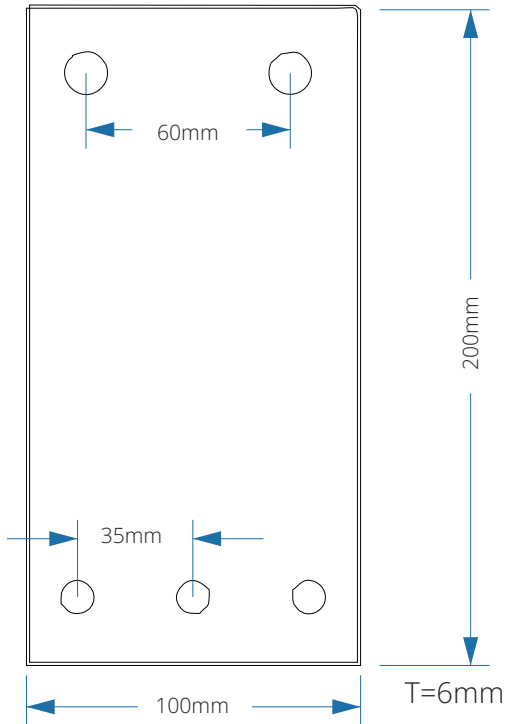

## Post Bracket

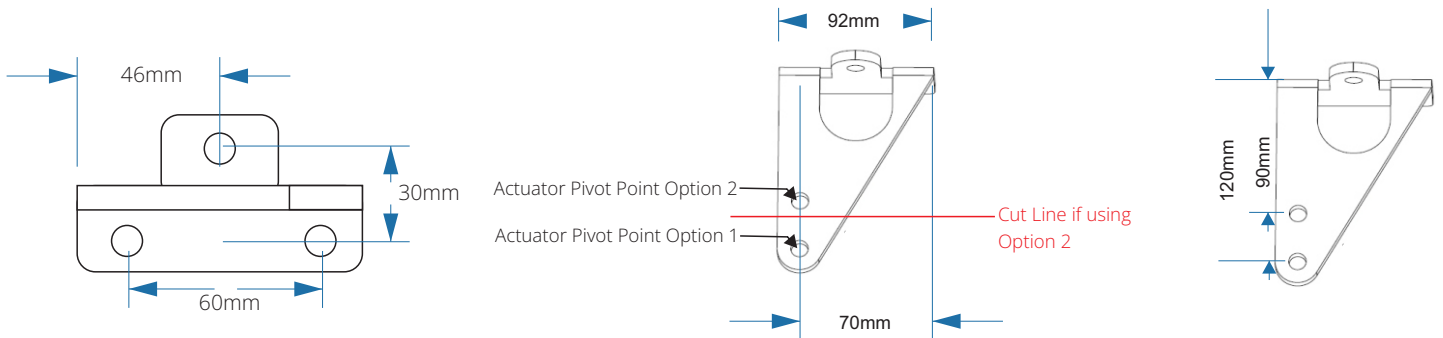

## Round Timber Posts

Cut a Niche to allow for a flat installation surface.  
Use Coach Bolt or Coach Screws for Fixing

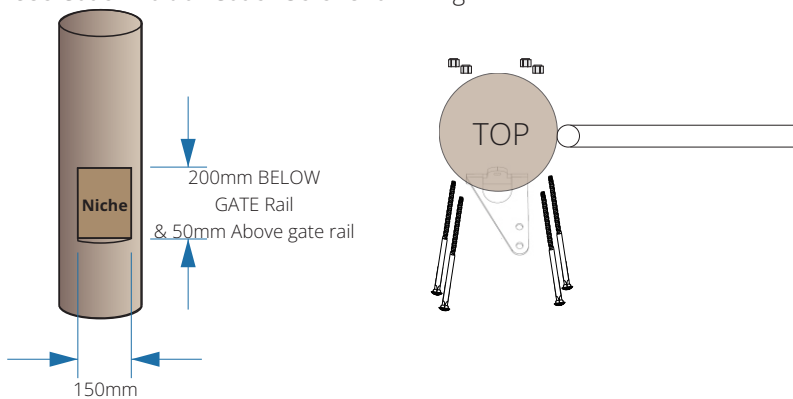

## Farm Gates

Drill Holes according to correct placement of riser plate.  
Use bolts and nut to install to the gate

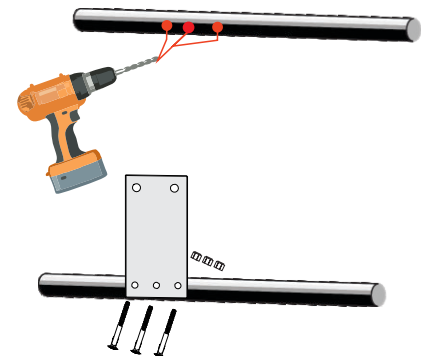

# Pull To Open Installation (Gate opens TOWARDS the motor)

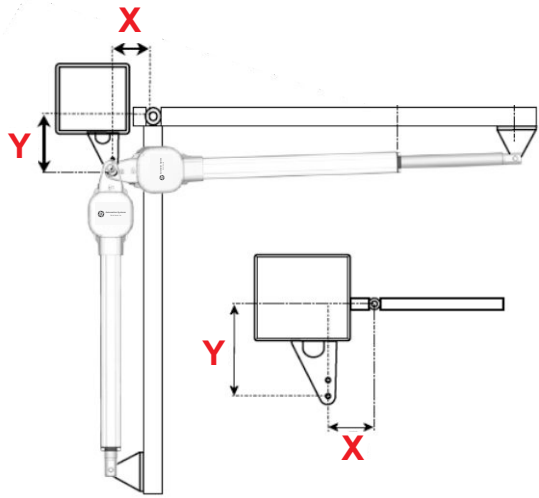
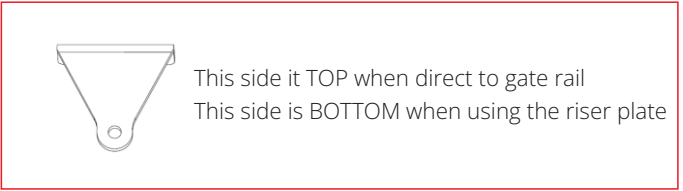
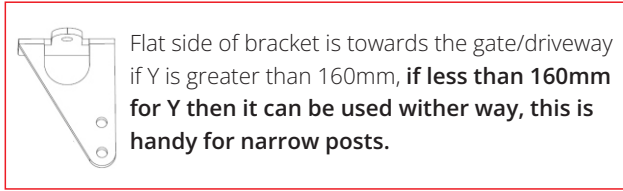

## Adhere to the X and Y Geometry range

The post bracket can be cut to a shorter length if required and the pivot hole re-drilled.

All measurements are made from the centre of the pivot hole to the centre of the hinge.

X = 90mm Min. (90°)/110mm Min. (100°)

Y = 140mm - 200mm/250mm

Up to 200mm Max (Viper 424)- Exceeding 180mm will effect the ability to use closed position limit stop, a physical gate stop would then be required.

Up to 250mm Max (Viper 524)

Exceeding 230mm will effect the ability to use closed position limit stop, a physical

## Step 1

First draw a vertical line to mark the X position according to the geometry, this must be adhered to.

Next draw a centre line from the gate rail to the post then Install the actuator POST bracket based on the following conditions:

1. If using the riser plate the centre of the post bracket will be installed 140mm higher than the gate rail centre, see method 1.

OR

2. If the required clearance is available for direct mounting to a horizontal rail the post bracket will be installed centred to the horizontal rail, see method 2.

Refer to actuator placement on page 2 if in doubt.

**NEVER INSTALL THE ACTUATOR UPSIDE DOWN**

**Method 1:** When the gate rail is less than 200mm from ground level, the supplied riser plate is used.

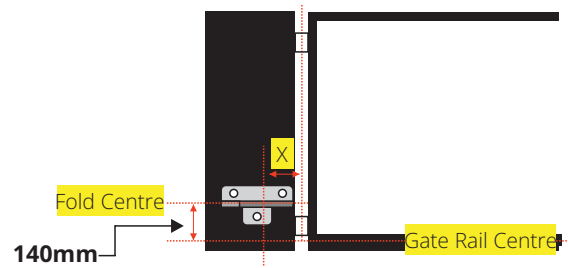

**Method 2:** When the gate rail is 200mm or greater from ground level.

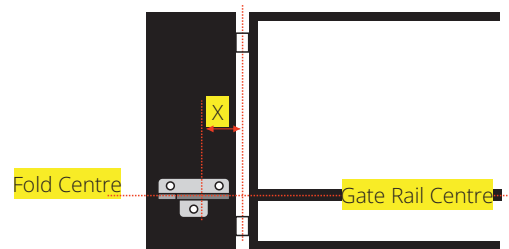

## Step 2

COMPLETELY Open the gate to the installation OPEN position (90°-100°) based on the requirement and geometry installation.

### VIPER 424

MEASURE from the **post bracket pivot point** to the gate face diagonally and mark the position at **750mm** this is the centre point of the gate bracket/riser plate.

### VIPER 524

MEASURE from the **post bracket pivot point** to the gate face diagonally and mark the position at **850mm** this is the centre point of the gate bracket/riser plate.

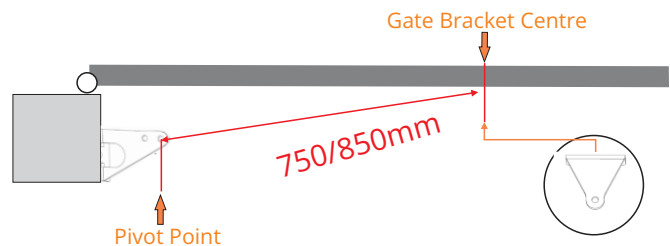

### Step 3

If Step 1 used **method 1** install with the riser plate. Ensure the FOLD of the brackets are level to one another. Riser Plate Assembly-Pg. 3, **Ensure the 3 fixing screws are centred to the gate rail.**

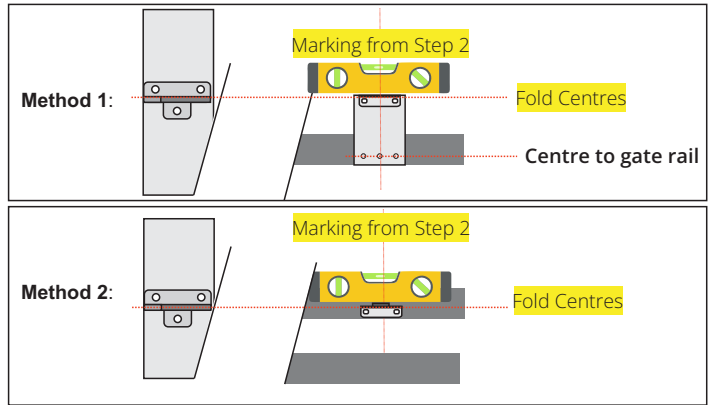

If Step 1 used **method 2** then Install the gate bracket to the gate using the appropriate fasteners. Ensure the FOLD of the brackets are level to one another.

### Optional

If desired and also suitable the kit is supplied with a gate and post bracket fascia covers that can slide into place to hide the assembly screws. These are optionally installed now. They are not mandatory to install so none/post side/post and gate can be installed as suited.

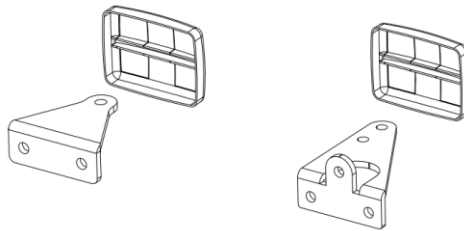

### Step 4

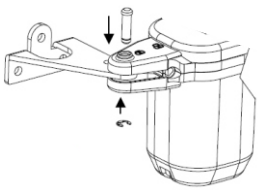

Install the actuator on the post bracket with the pin and secure the pin with the C clip.

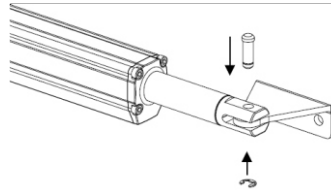

Install the actuator on the gate bracket with the pin and secure the pin with the C clip.

### Step 5

Manually release the actuator so that the gate can be manually operated (unlocked).

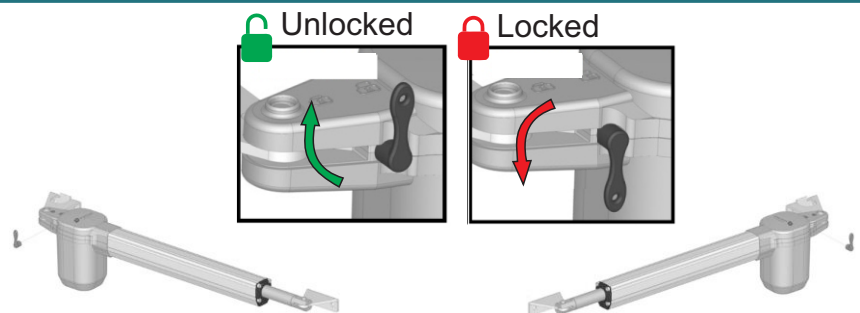

### Step 6

Close the gate and using a 6mm Allen key LOOSEN **SLIGHTLY** the closed position limit stop. adjust the closed position limit stop against the piston stopper. Now tighten the limit stop, this is the closed position set.

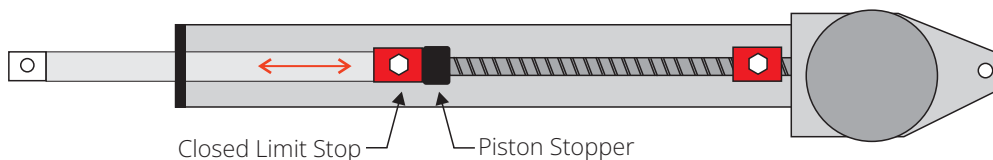

### Step 8

Open the gate and using a 6mm Allen key LOOSEN **SLIGHTLY** the open position limit stop. adjust the Open position limit stop against the piston stopper. Now tighten the limit stop, this is the open position set.

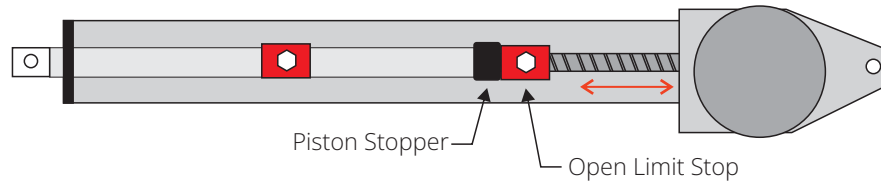

### Step 7

Re-Engage (Lock) the actuator in the full open Position.

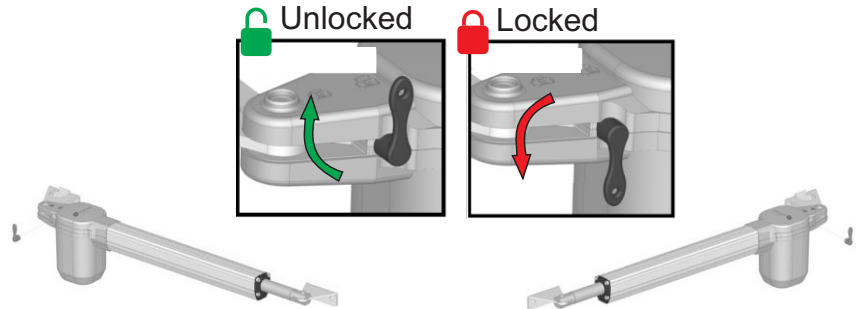

## DOUBLE GATES: REPEAT ALL STEPS FOR THE SECOND ACTUATOR

### Step 8

Follow the illustration bellow for the connection to the Premier 24 Swing Gate Controller paying attention to the **Motor 2 connection being the master gate** and Motor 1 Connection being the Second Motor for Double Gates.

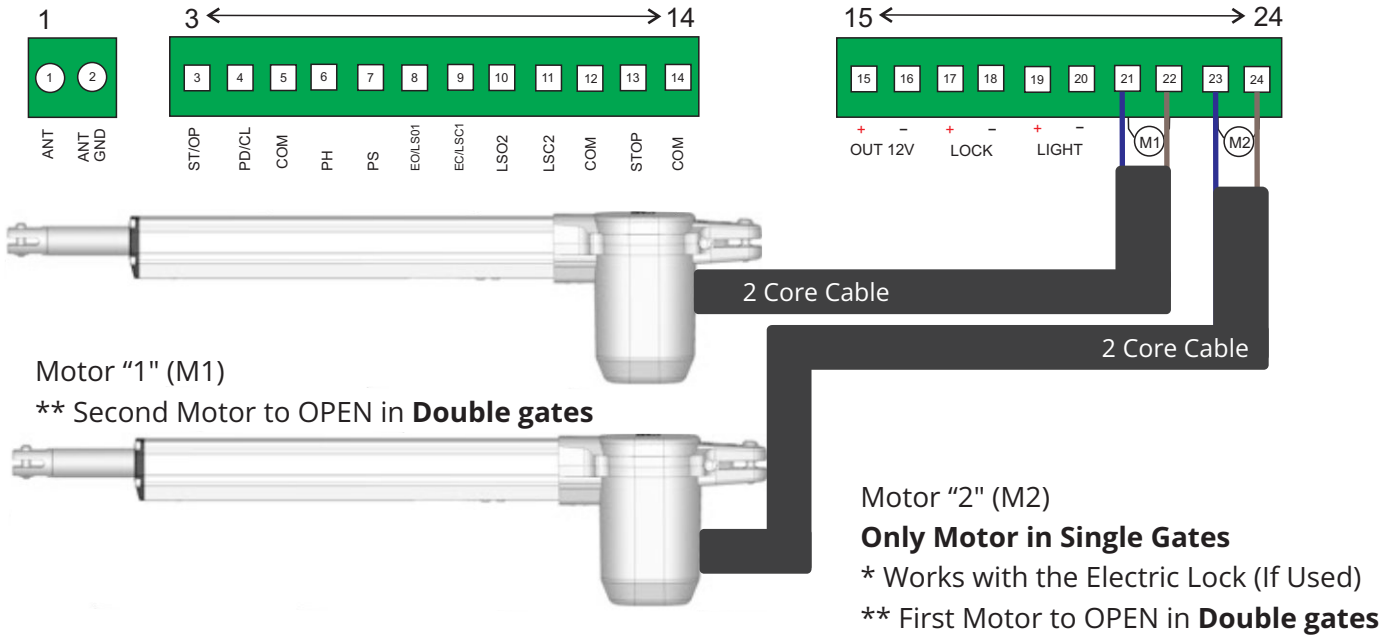

# Push To Open Installation (Gate opens AWAY from the motor)

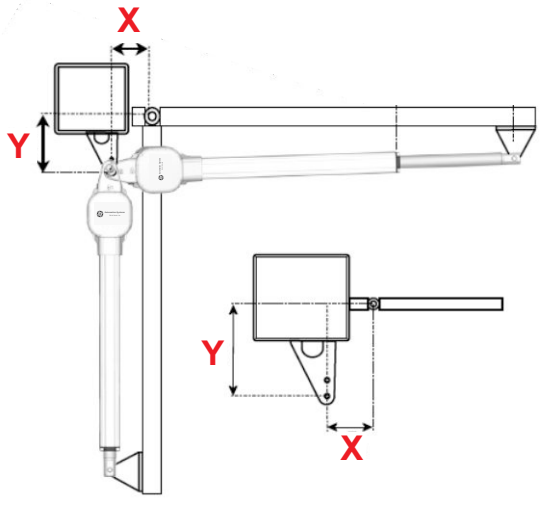
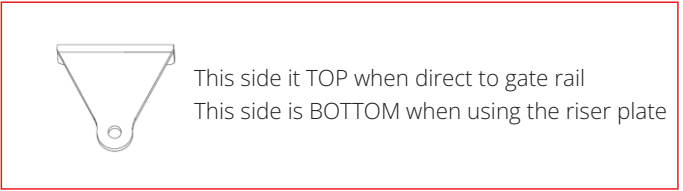
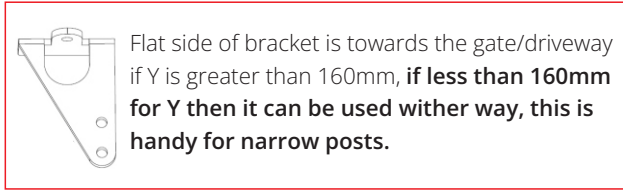

### Adhere to the X and Y Geometry range

The post bracket can be cut to a shorter length if required and the pivot hole re-drilled.

All measurements are made from the centre of the pivot hole to the centre of the hinge.

$$X = 90\text{mm Min. (90°)}/110\text{mm Min. (100°)}$$

$$Y = 140\text{mm} - 200\text{mm}/250\text{mm}$$

Up to 200mm Max (Viper 424)- Exceeding 180mm will effect the ability to use closed position limit stop, a physical gate stop would then be required.

Up to 250mm Max (Viper 524)

Exceeding 230mm will effect the ability to use closed position limit stop, a physical

## Step 1

First draw a vertical line to mark the X position according to the geometry, this must be adhered to.

Next draw a centre line from the gate rail to the post then Install the actuator POST bracket based on the following conditions:

1. If using the riser plate the centre of the post bracket will be installed 140mm higher than the gate rail centre, see method 1.

OR

2. If the required clearance is available for direct mounting to a horizontal rail the post bracket will be installed centred to the horizontal rail, see method 2.

Refer to actuator placement on page 2 if in doubt.

**NEVER INSTALL THE ACTUATOR UPSIDE DOWN**

**Method 1:** When the gate rail is less than 200mm from ground level, the supplied riser plate is used.

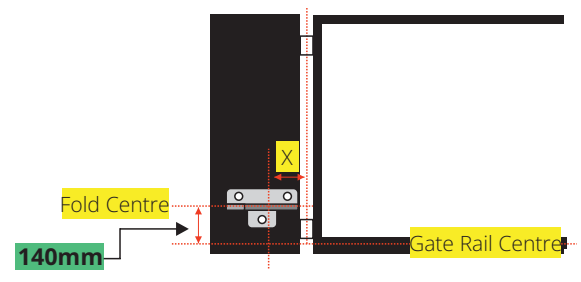

**Method 2:** When the gate rail is 200mm or greater from ground level.

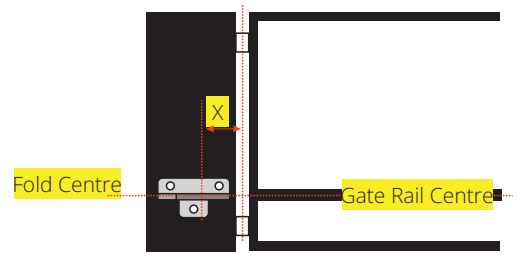

## Step 2

COMPLETELY Close the gate to the installation CLOSED position.

### VIPER 424

MEASURE from the post bracket pivot point to the gate face diagonally and mark the position at 750mm this is the centre point of the gate bracket/riser plate.

### VIPER 524

MEASURE from the post bracket pivot point to the gate face diagonally and mark the position at 850mm this is the centre point of the gate bracket/riser plate.

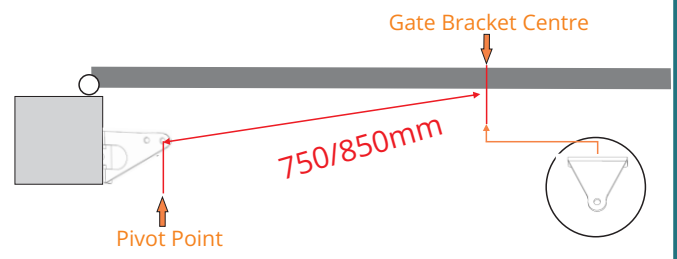



### Step 3

If Step 1 used **method 1** install with the riser plate. Ensure the FOLD of the brackets are level to one another.  
Riser Plate Assembly-Pg. 3 **Ensure the 3 fixing screws are centred to the gate rail.**

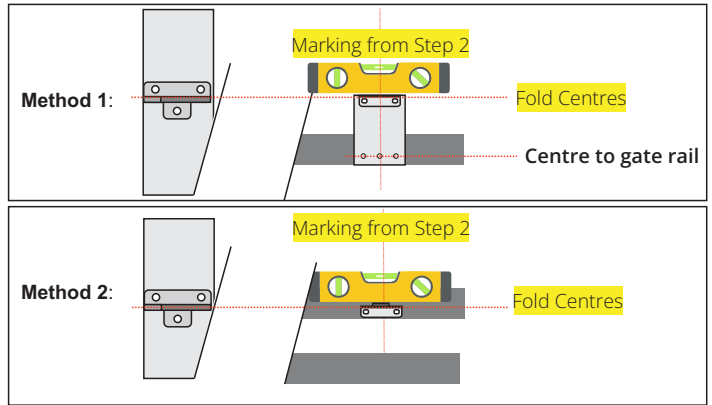

If Step 1 used **method 2** then Install the gate bracket to the gate using the appropriate fasteners. Ensure the FOLD of the brackets are level to one another.

### Optional

If desired and also suitable the kit is supplied with a gate and post bracket fascia covers that can slide into place to hide the assembly screws. These are optionally installed now. They are not mandatory to install so none/post side/post and gate can be installed as suited.

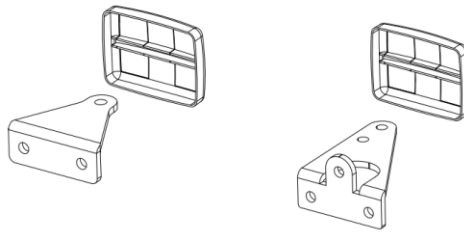

### Step 4

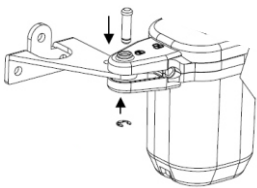

Install the actuator on the post bracket with the pin and secure the pin with the C clip.

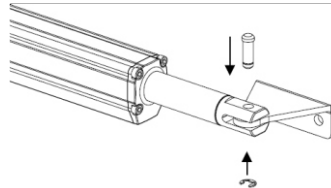

Install the actuator on the gate bracket with the pin and secure the pin with the C clip.

### Step 5

Manually release the actuator so that the gate can be manually operated (unlocked).

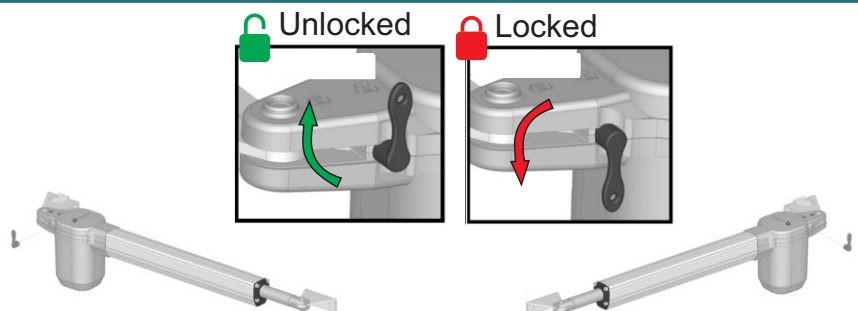

### Step 6

Close the gate and using a 6mm Allen key LOOSEN **SLIGHTLY** the closed position limit stop. adjust the closed position limit stop against the piston stopper. Now tighten the limit stop, this is the closed position set.

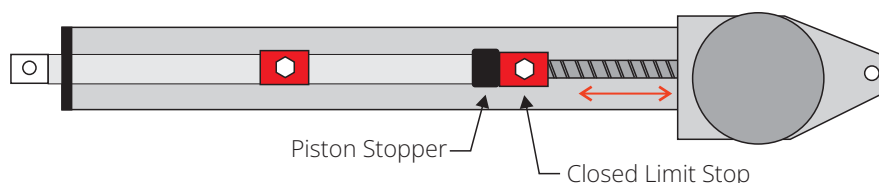

cont. Push To Open Installation (Gate opens AWAY from the motor)

## Step 8

Open the gate and using a 6mm Allen key **LOOSEN SLIGHTLY** the open position limit stop. adjust the Open position limit stop against the piston stopper. Now tighten the limit stop, this is the open position set.

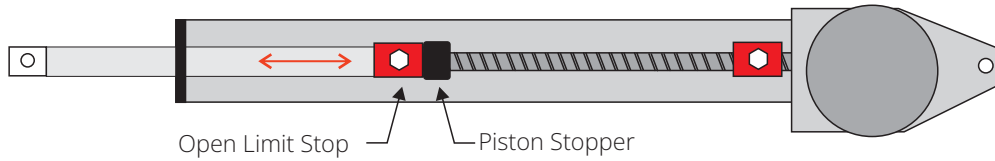

## Step 7

Re-Engage (Lock) the actuator in the full open Position.

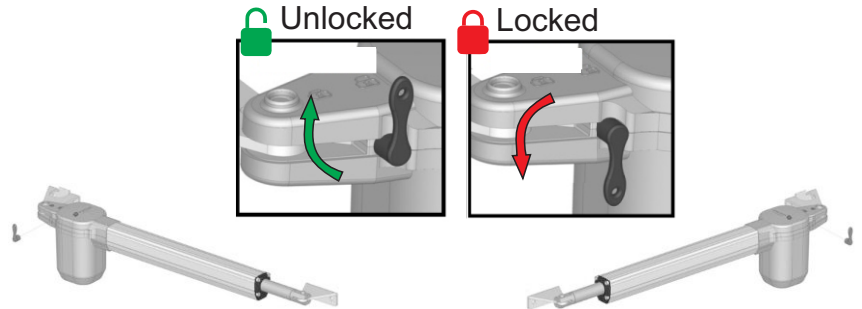

## DOUBLE GATES: REPEAT ALL STEPS FOR THE SECOND ACTUATOR

## Step 8

Follow the illustration bellow for the connection to the Premier 24 Swing Gate Controller paying attention to the **Motor 2 connection being the master gate** and Motor 1 Connection being the Second Motor for Double Gates.

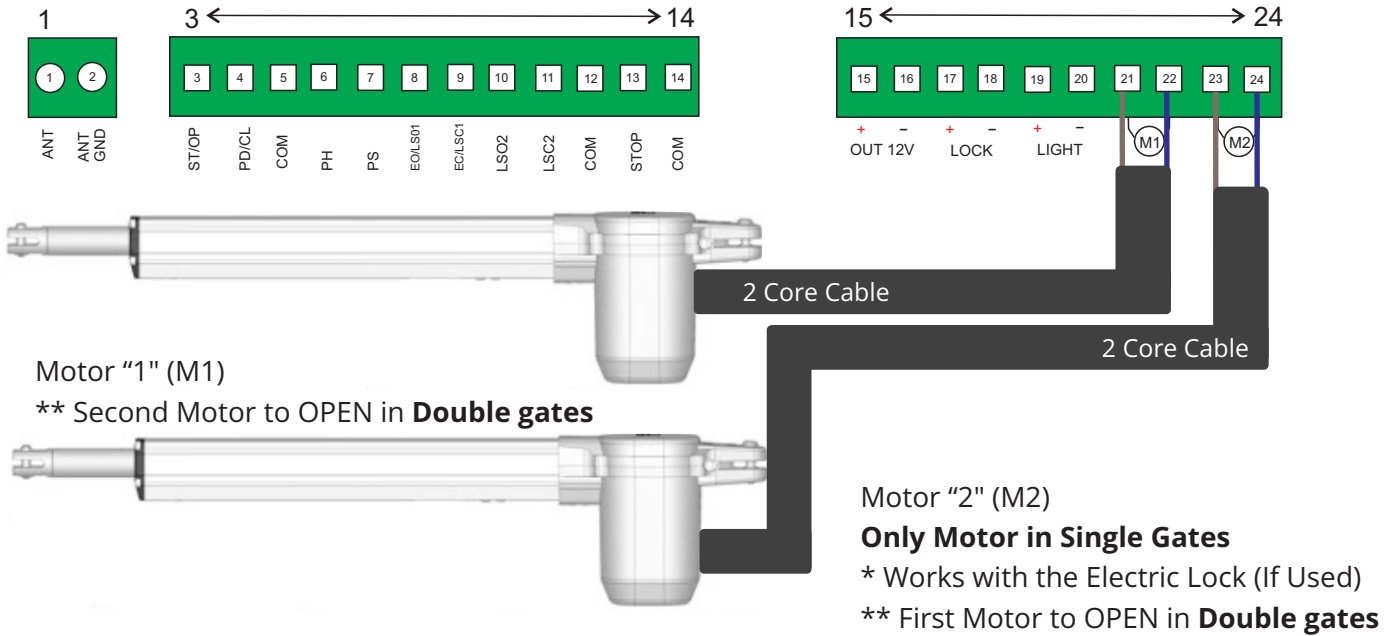

## Warranty Terms and Conditions

The product is warranted for a period of 36 months (3 years) from the date of purchase, unless expressly specified as extended warranty (extension to the warranty period). The product is to be installed for its intended purpose and for normal use as outlined within the installation manual, the product warranty is exclusively for defects in manufacturing and manufacturing workmanship. It does not cover out of guidelines use, natural or other disasters, abnormal weather conditions, damage incurred in shipping or handling, damage caused by disaster such as fire, flood, wind, earthquake, lightning, excessive voltage, mechanical shock, water damage, damage caused by unauthorized attachment, alterations, modifications, or foreign objects, damage caused by peripherals (unless such peripherals were supplied by Automation Systems Australia), defects caused by failure to provide a suitable installation environment for the products, damage caused by usage of the products for purpose other than those for which it was designed, damage from improper maintenance, damage arising out of any other abuse, mishandling, and improper application of the products.

At is discretion Automation Systems Australia will require the item determined by the support staff to be returned to base in it original unmodified condition for a warranty inspection if within the warranty period. A return authorization "RA" number will be provided to be enclosed with the product in question. The warranty will not cover freight fees to base, customs fees or any labour costs at the installation site but will cover repair or replacement of the product as seen fit. Automation Systems Australia will cover the freight of the returned item to the original address if deemed as a warranty repair or replacement item. Any warranty repairs or replacements continue to carry through the remaining warranty period and do not extend or restart the period.

Under no circumstances shall Automation Systems Australia be liable for any special, incidental, or consequential damages based upon breach of warranty, breach of contract, negligence, strict liability, or any other legal theory. Such damages include, loss of profits, loss of the product or any associated equipment, cost of capital, cost of substitute or replacement equipment, facilities or services, down time, purchaser's time, the claims of third parties, including customers, and injury to property.

This warranty contains the entire warranty and shall be in lieu of any and all other warranties, whether expressed or implied (including all implied warranties of merchantability or fitness for a particular purpose). And of all other obligations or purporting to act on its behalf to modify or to change this warranty, nor to assume for it any other warranty or liability concerning this product.

Automation Systems Australia will at its option repair or replace out-of-warranty products at a determined cost which are returned to its base according to the following conditions. Anyone returning goods to Automation Systems Australia must first obtain an authorization number. Automation Systems Australia will not accept any shipment whatsoever for which prior authorization has not been obtained. Products which Automation Systems Australia determines to be repairable will be repaired and returned. A set fee which Automation Systems Australia has been predetermined and which may be revised from time to time will be charged for each unit repaired. Products which Automation Systems Australia determines not repairable will be replaced by the nearest equivalent product available at that time. The current market price for the replacement product will be charged for each replacement unit.