

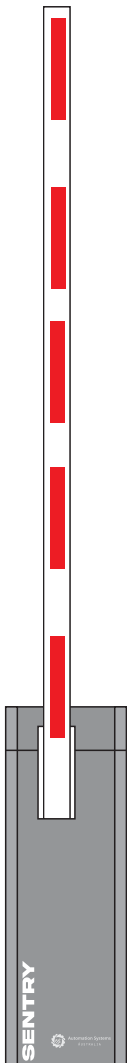

# Automation Systems AUSTRALIA

## SENTRY

Advanced Digital Boom Gate Operator



**SENTRY**

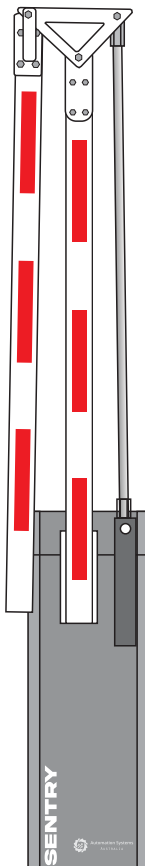

**SENTRY  
A180**

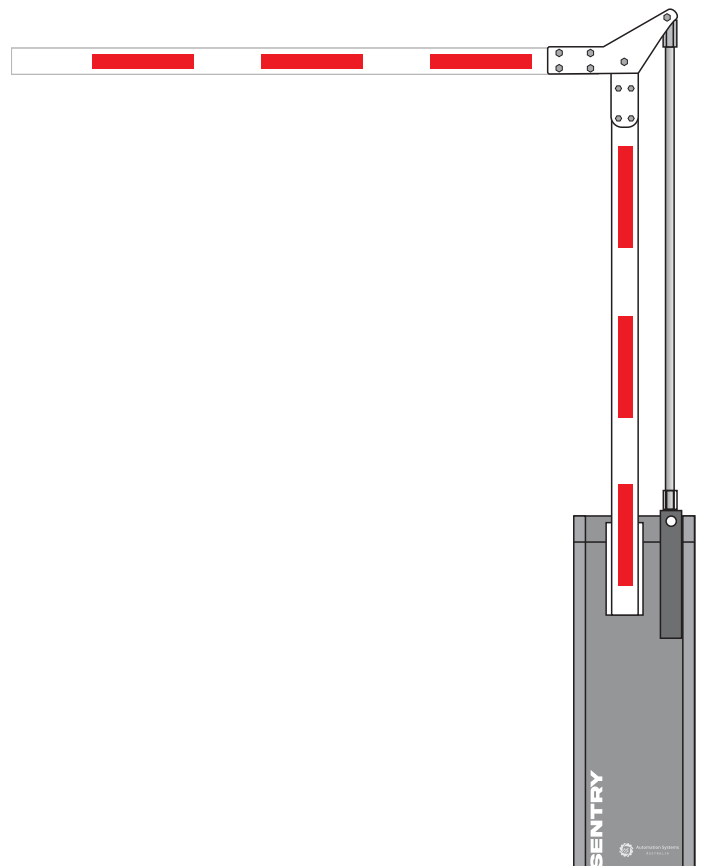

**SENTRY  
A90**



Step by Step Simple Installation  
Guide on Page 4

# Table of Contents

1	Specifications, Dimension and Tools Required
2	System Installation Layout Pt.1
3	System Installation Layout Pt.2 (Loops), Spring system and Sizing
4	Step by Step Installation Guide, Manual Release
5	Left and Right Side Configurations
6	STRAIGHT ARM Boom Gate Installation
7	STRAIGHT ARM Boom Gate Installation Cont.
8	Calculating the ARTICULATION ARM Lengths 90° and 180°
9	Setting the ARTICULATION ARM Lengths 90° and 180°
10	ARTICULATION ARM Boom Gate Installation
11	ARTICULATION ARM Boom Gate Installation Cont.
12	ARTICULATION ARM Boom Gate Installation Cont.
13	Control Board Layout, Internal Power Supply Connection
14	Solar System Connection
15	Wireless Expander and Remotes
16	Photocells Dukie and Dukie+ (Safety Device)
17	Photocells Dukie and Dukie+ (Detector)
18	Traffic Lights, Open-Closed Position Relays, Emergency Stop, Tekno Wi-Fi Control
19	Tekno Keypad, Push Buttons, Tekno GSM Intercom, Weekly Timer
20	Induction Loops
21	Automatic Closing and system Settings, Troubleshooting
22	Warranty Terms

# Specifications

Operating Voltage	24V DC
Standby Consumption	~50mA
Motor Type	Brushless 24V 150W
Speed	Adjustable 2.4-8 seconds depending on arm length/type
Motor Limit Support	Hall Sensor
Light Output	Light bar and traffic light support
Accessories Power	24V DC (250mA)
Safety Inputs	Photocell, Detector, Induction Loop
Operation Temperature	-30°C to +70°C
Remote Button Capacity	16 Admins
Duty Cycle	80%

# Dimensions and Footings

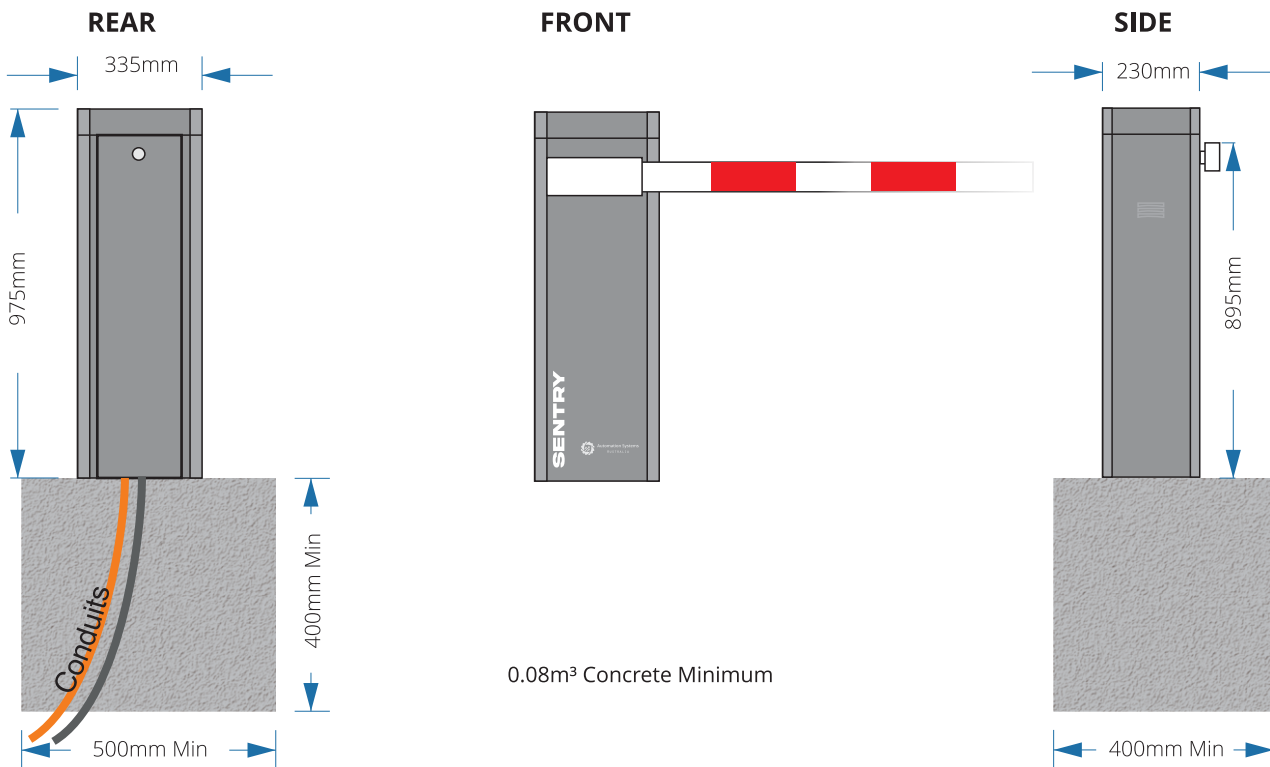

# Installation Layout (Accessories)

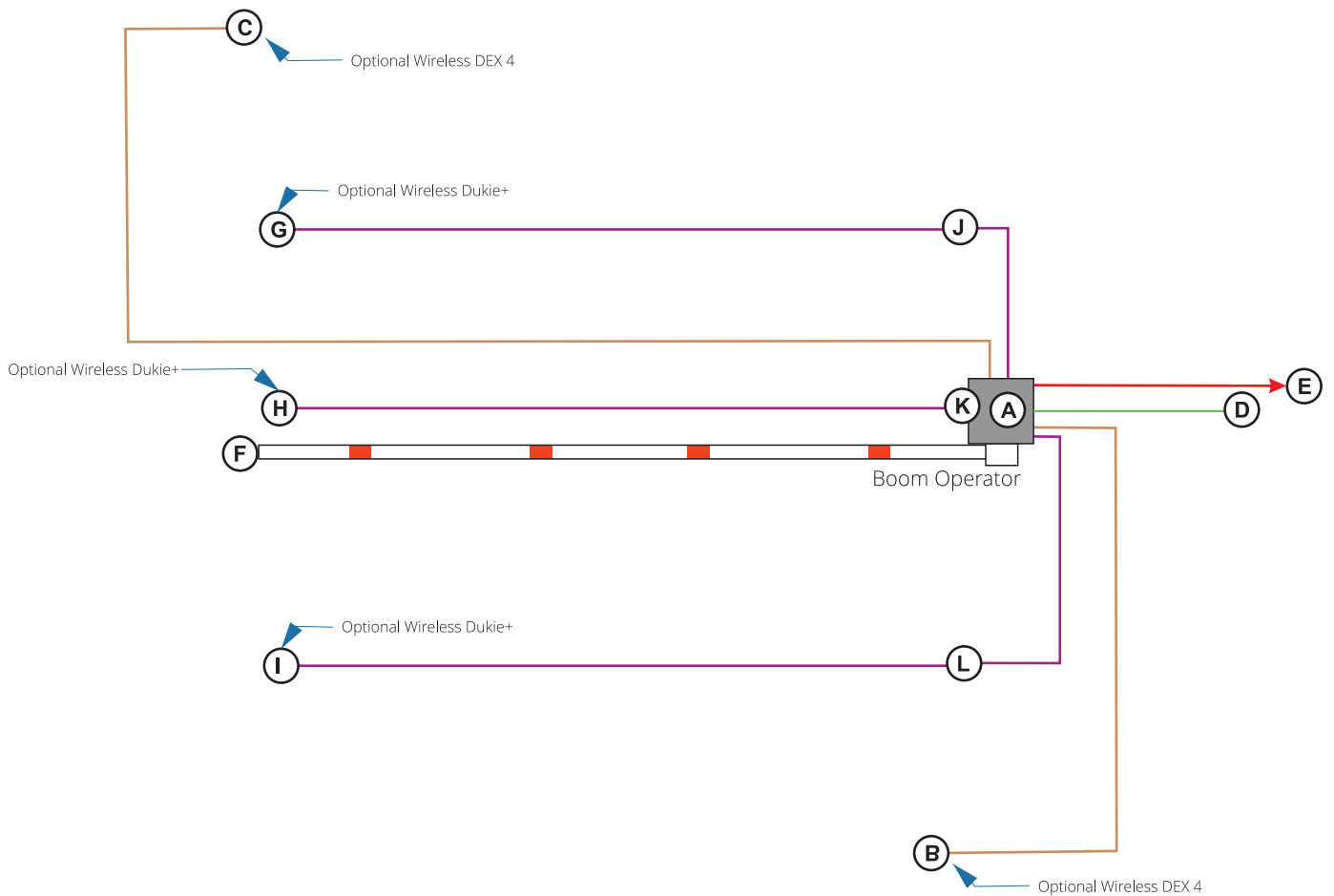

Number	Accessory	Requirements
A	Boom Operator	Power by transformer or Solar
B	Entry Keypad	Dex 4 (wireless), All others wired to gate controller by 4 core cable
C	Exit Keypad	Dex 4 (wireless), All others wired to gate controller by 4 core cable
D	Emergency Stop Button	2 Core cable to boom operator
E	Power Source	Mains, External Transformer or Solar Panel to the Gate Controller
F	Resting Point Cradle	Resting point for arm
G-H-I	Transmitter Photocell	2 Core cable to boom operator, DUKIE XR uses a reflector
J	Photocell Receiver (Opening Device)	4 Core cable to boom operator
K	Photocell Receiver (Safety Device)	4 Core cable to boom operator
L	Photocell Receiver (Detector for Closing Device)	4 Core cable to boom operator

## Installation Layout (Induction Loops)

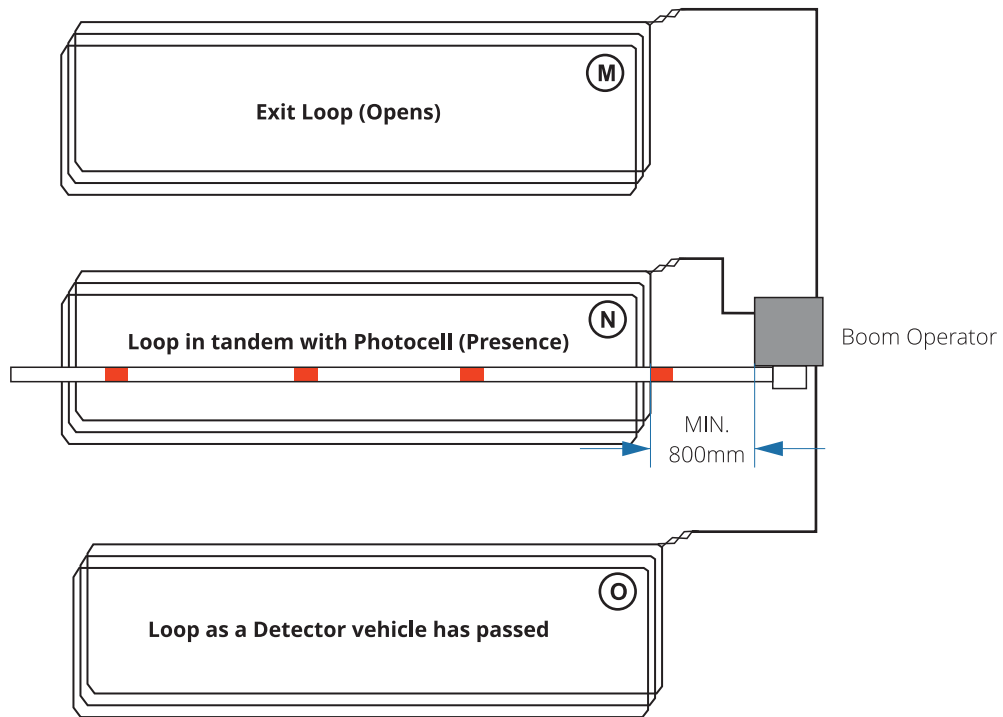

Number	Accessory	Requirements
M	Loop Detector (Opening Device)	1 Core cable to boom operator (to loop detector device)
N	Loop Detector (Safety Device)	1 Core cable to boom operator (to loop detector device)
O	Loop Detector (Detector for Closing Device)	1 Core cable to boom operator (to loop detector device)

## Spring System

Spring packs are pre-installed into the system based on the nominated arm size during purchase. Springs can be replaced at any time if the arm size is to be increased/decreased.

### Straight Arm Spring Packs

6m Arm 4.5+5.5  
 5m Arm 4.0+5.5  
 4.5m Arm 4.5+4.5  
 4m Arm 4.5+4.0  
 3.5m Arm 4.5  
 3m Arm 4.5

### Articulation Arm Spring Packs

5m Arm 5.5+4.5  
 4.5m Arm 5.5+4.5  
 4m Arm 4.5+4.5  
 3.5m Arm 4.5+4.5  
 3m Arm 4.5+4.0

### Reference

5.5 blue  
 4.5 red  
 4.0 green

# Step by Step Installation Guide

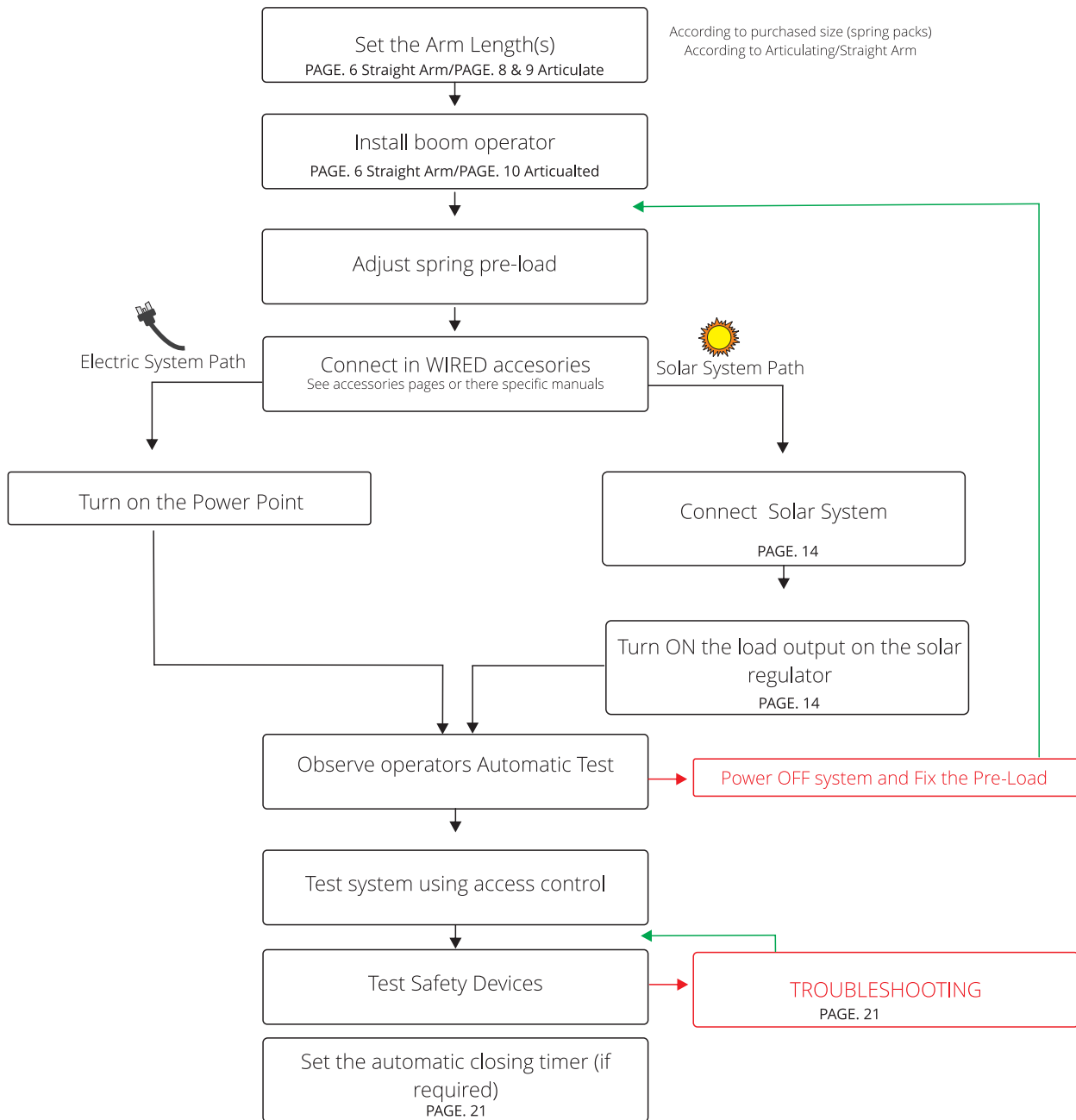

## Manual Release



The system can be raised and lowered when the system power is lost/OFF, the breaker switch MUST also be turned to the OFF position if not and the power is restored whilst using manual operation it may cause injury.

Clockwise and Anti-Clockwise rotations will result in upwards and downwards movement.

Ensure the Arm returns to the down position after vehicle has passed, **without the system power** the arm cannot be locked in the UP position and risks closing on its own.

## "Left" Side Operator

## "Right" Side Operator

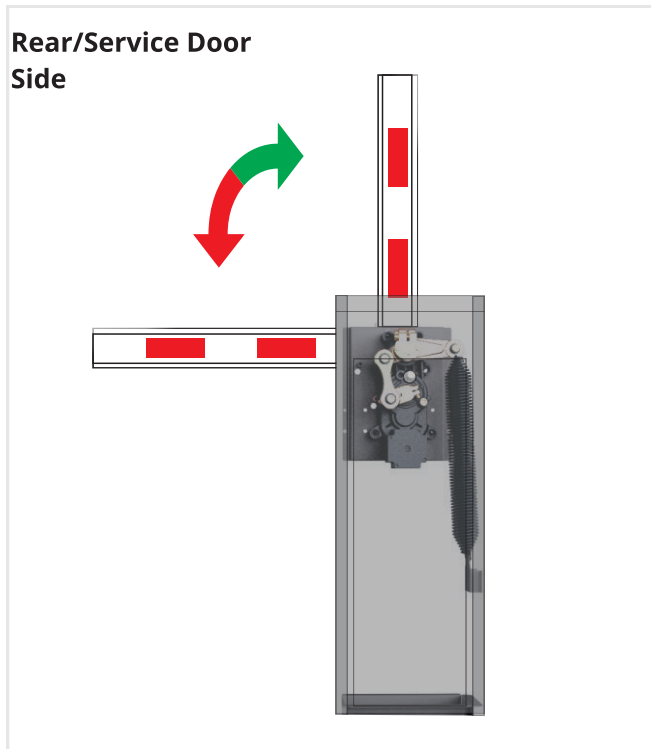
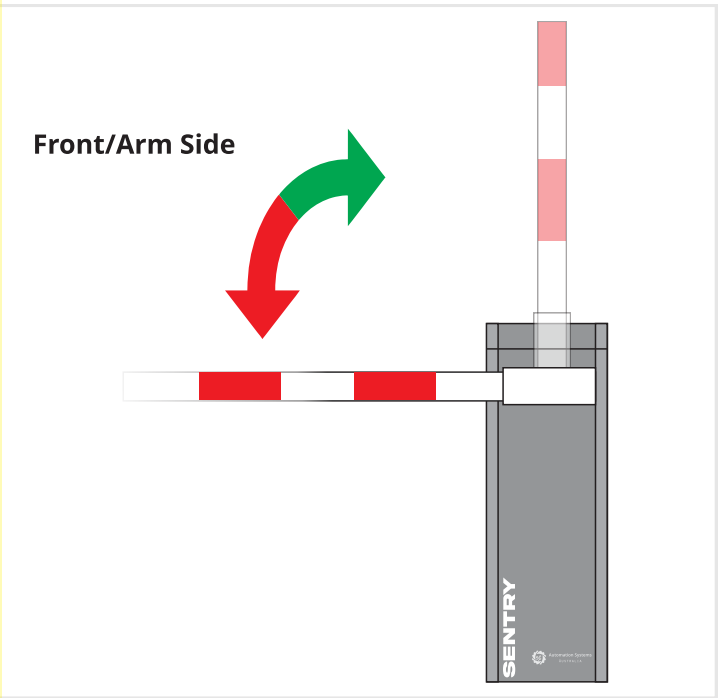
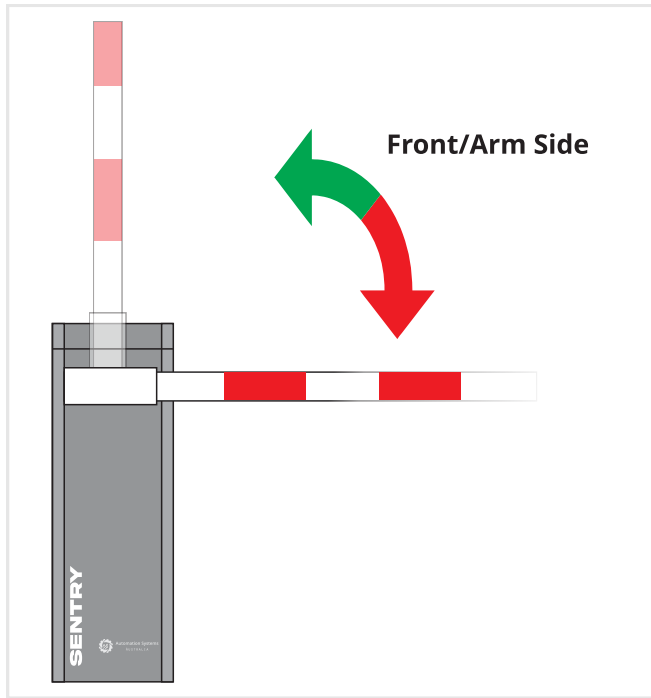

**IDENTICAL UNITS- Linkage system opposite to one another**

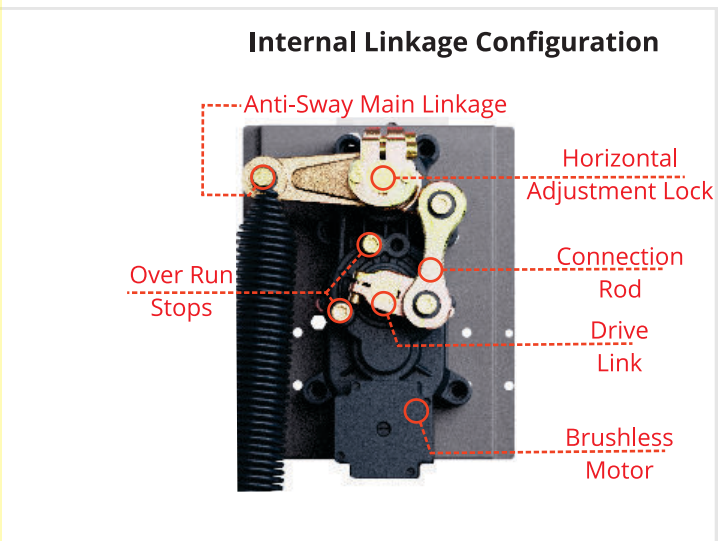
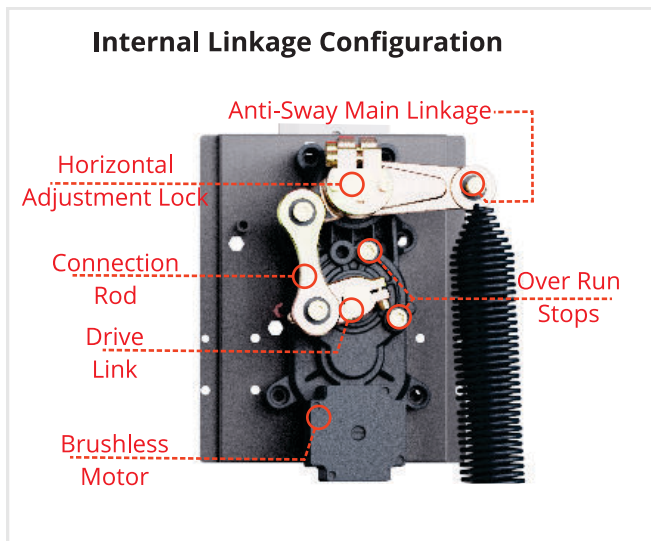

# Straight Arm Boom Gate Installation

1

Install the operator using the TWO clamp plates and FOUR dynabolts

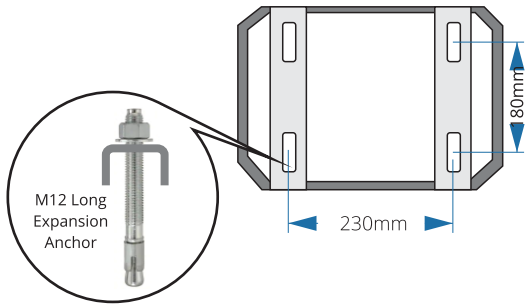

2

Install the boom arm and clamp plate to the boom gate. The trailing arm will need to be supported as the master arm is installed

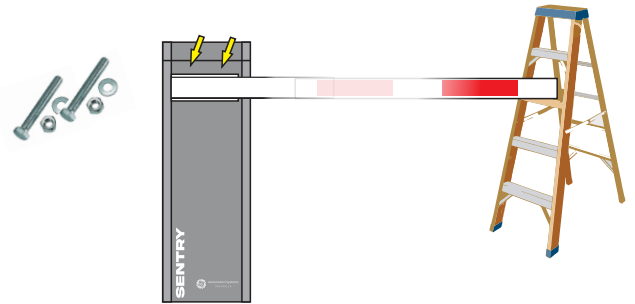

3

Adjust the arm in/out to achieve the required size and fix in place using screws through the body of the main arm into the body of the secondary arm.

**Make a hole in the primary arm to match with the rivet nut which is pre-installed in the secondary arm.**  
**THE FIXING BOLT IS STORED BEHIND CAP "A"**

Secondary extension arm push in/Pull out of first to achieve the required length.



**Do not change from the initial ordered size as the balancing springs provided in the kit are to suit.**

4

- Unlock and remove the service door.
- Remove the two top lid retaining screw
- Tilt the cover forward toward the boom arm and up to remove.

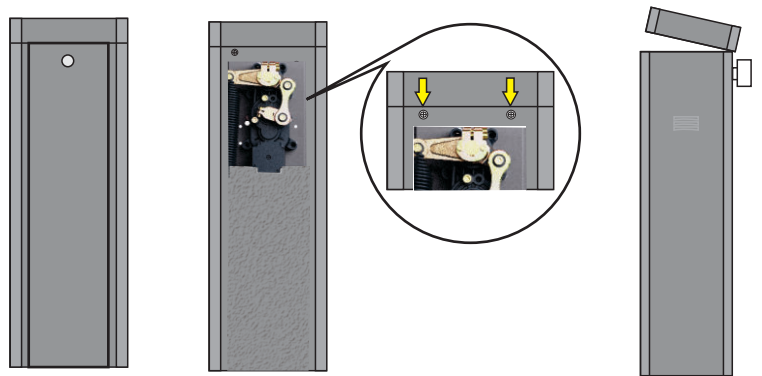

5

ONLY IF NECESSARY Loosen the three bolts detailed below push the master arm up/down to achieve level then re-tighten the bolts.

**ENSURE THE OPERATOR IS NOT POWERED ON**

Whilst de-powered the operators arm can be moved which will rotate the operating assembly inside.

- Move the arm til the M12 bolt is accessible from the top, loosen the M12 bolt but do not remove.
- Rest the arm in the naturally occurring closed position.
- Loosen the M6 bolts but do not remove.
- Adjust the arm to the correct horizontal Level.
- Tighten the M6 bolts.
- Tighten the M12 bolt.

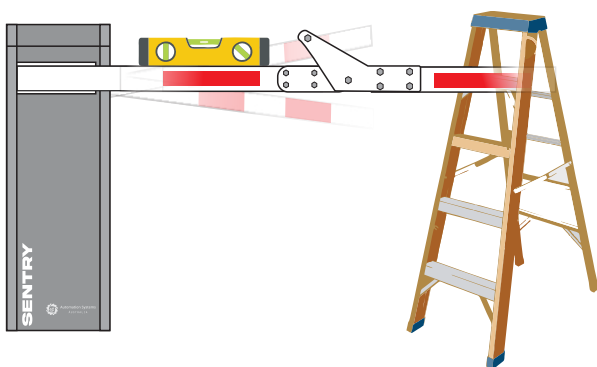

M6 Allen Bolt  
Aligns Main Link to Main Shaft  
(Breaker Bar Required)

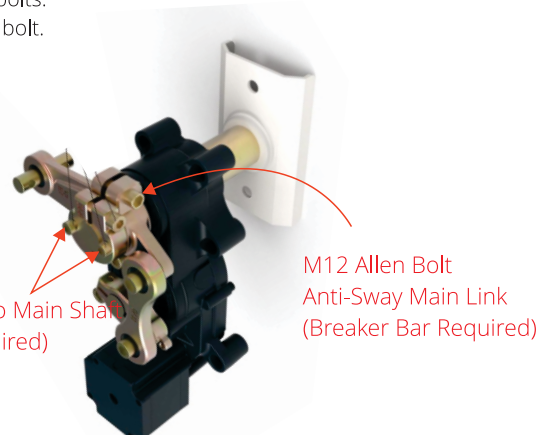

M12 Allen Bolt  
Anti-Sway Main Link  
(Breaker Bar Required)



Balancing springs are pre-installed based on the chosen size during purchasing, they will need adjustment based on the observation of the arm. Each time the system is turned ON it will slowly OPEN (UP) and CLOSE (DOWN) the boom arm.



NEVER ADJUST WHILST THE OPERATOR IS IN MOTION (Turn the power OFF prior to each adjustment)

NEVER ADJUST WHILST THE SPRING IS IN ITS EXPANDED STATE

Always Loosen the locking nut prior to adjusting, Always tighten the locking nut prior to powering ON.

Turning ON the power to the system will trigger an automatic motion of UP and DOWN, this can be used to observe the operation in a slow speed. Any triggers by access control after the first motion will run the system at a normal speed.

You can power OFF when the arm is down and then power back on to observe the slow motion again.

Always power OFF the system between adjustments.,NEVER power OFF mid cycle as the arm will come racing down without a powered motor.

**The arm is travelling to  
UP/OPEN**

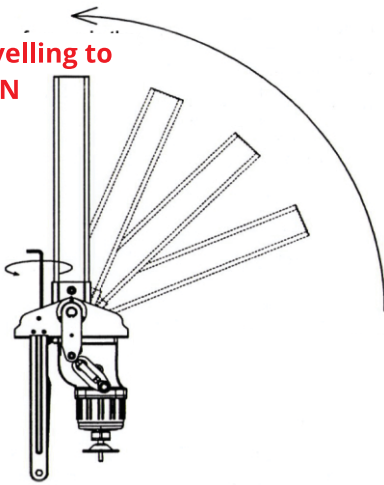

The arm shakes when it has reached/reaching the UP position this indicates the pre-load is too high, decrease the pre-load by adjusting anti-clockwise to loosen.

DUAL SPRINGS, ALWAYS ADJUST TOGETHER EQUALLY

**The arm is travelling to  
DOWN/CLOSE**

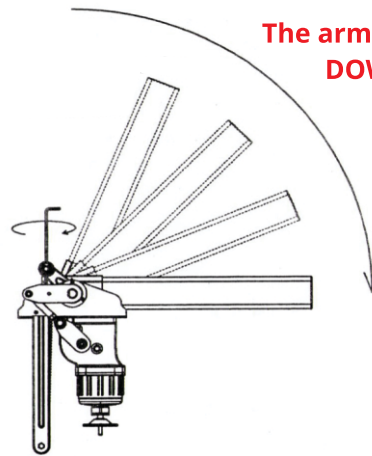

The arm shakes when it has reached/reaching the DOWN position this indicates the pre-load is too low, increase the pre-load by adjusting clockwise to loosen.

DUAL SPRINGS, ALWAYS ADJUST TOGETHER EQUALLY

## 90° Articulation Boom Arm Lengths

Calculatons of final arm lengths can occur based on two different restive scenarios

**Clear Height Scenario, when height is the restricting factor**

Clear Height -670mm -130mm= \_\_\_\_\_mm /2= Final for each Arm

**Available Width Scenario, when height is NOT the restricting factor**

Width-55mm= \_\_\_\_\_mm /2= Final for each Arm

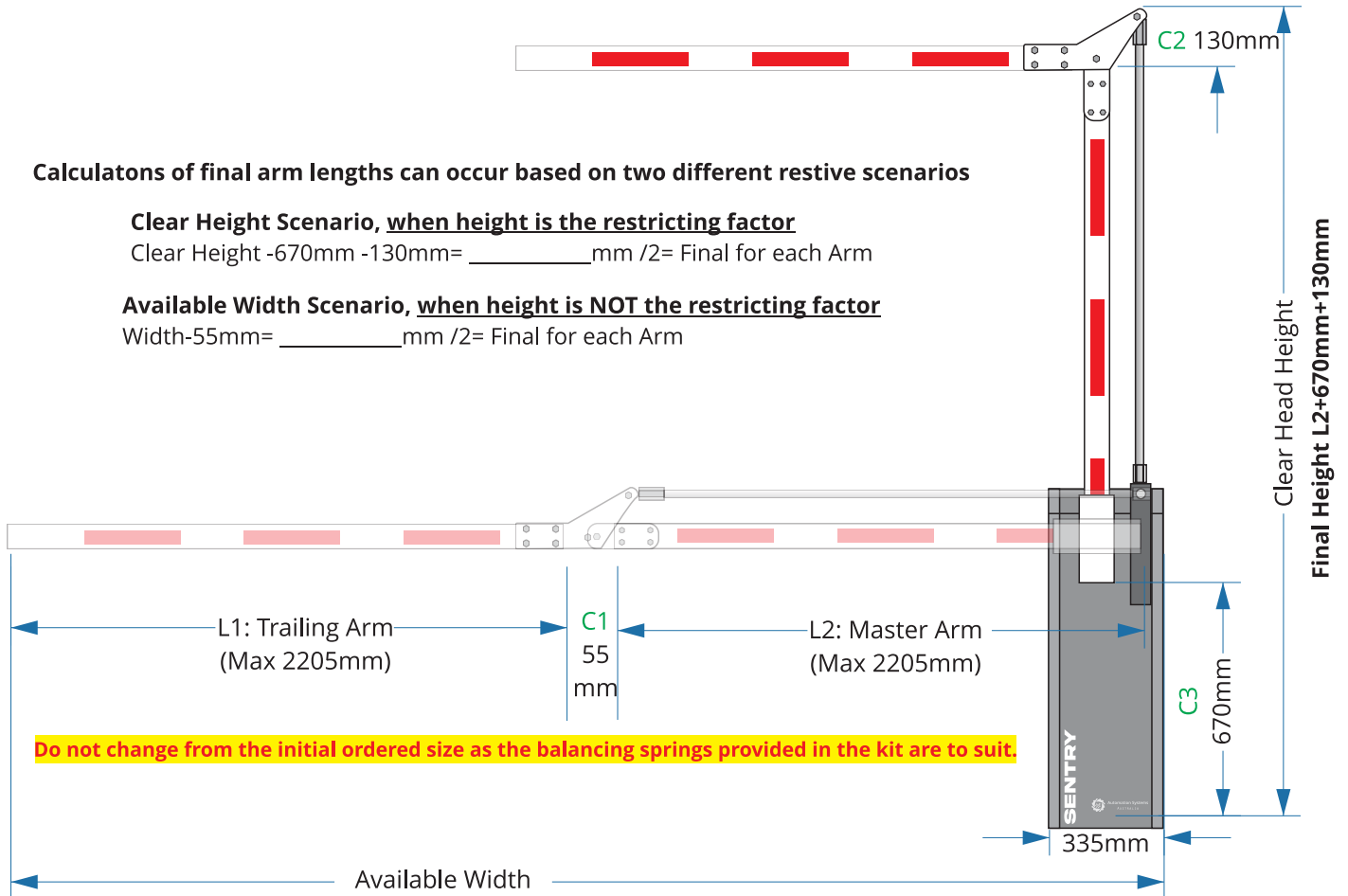

## 180° Articulation Boom Arm Lengths

Calculatons of final arm lengths can occur based on two different restive scenarios

**Clear Height Scenario, when height is the restricting factor**

Clear Height -670mm -90mm= \_\_\_\_\_mm /2= Final for each Arm

**Available Width Scenario, when height is NOT the restricting factor**

Width-130mm= \_\_\_\_\_mm /2= Final for each Arm

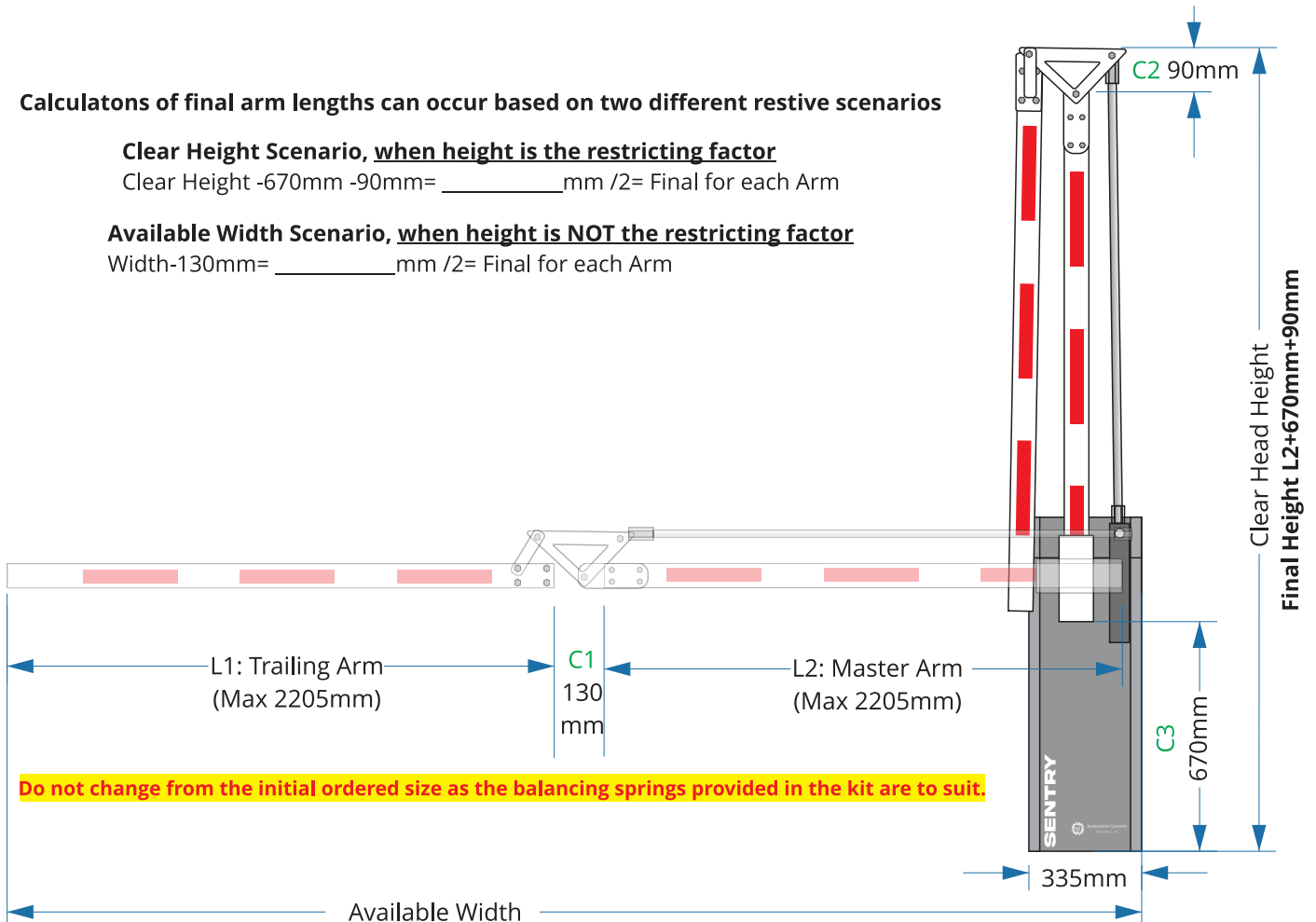

# 90° and 180° Articulation Arm Setting

Remove the anti crush inside and re-install after the cut and holes are made

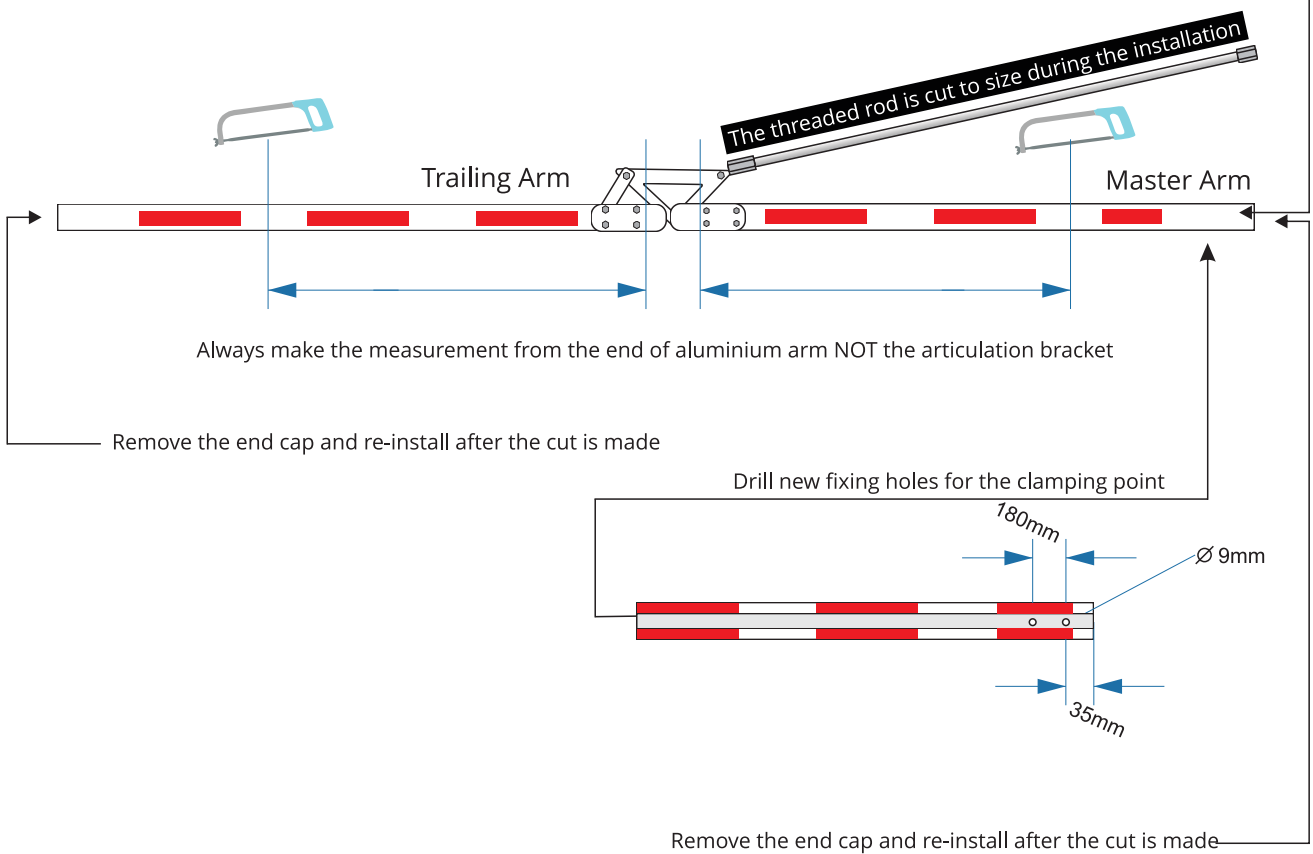

Do not change from the initial ordered size as the balancing springs provided in the kit are to suit.

# Articulating Boom Gate Installation

1

Install the operator using the TWO clamp plates and FOUR dynabolts

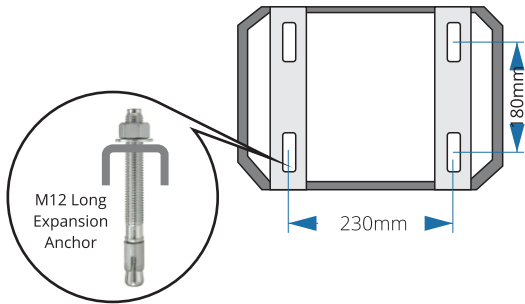

2

Install the articulating boom arm and clamp plate to the boom gate. The trailing arm will need to be supported as the master arm is installed

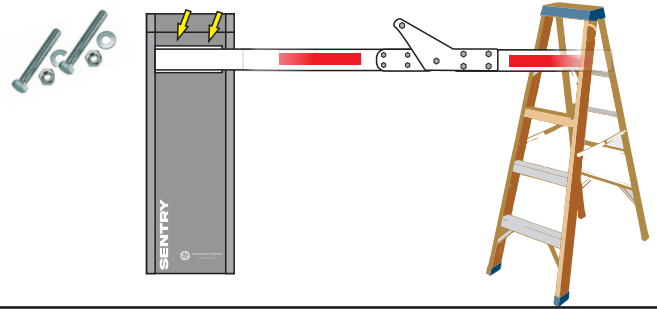

3

- Unlock and remove the service door.
- Remove the two top lid retaining screw
- Tilt the cover forward toward the boom arm and up to remove.

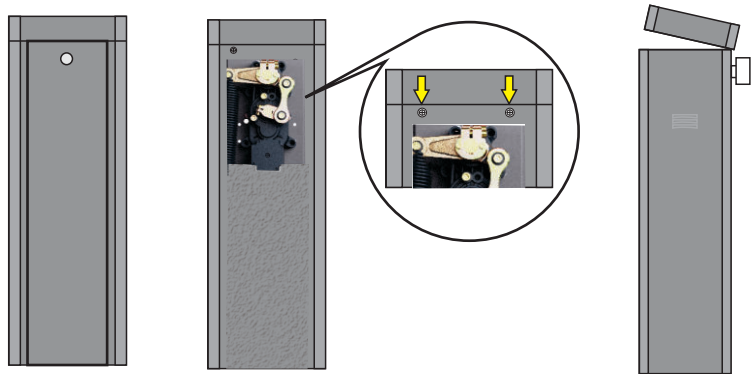

4

ONLY IF NECESSARY Loosen the three bolts detailed below push the master arm up/down to achieve level then re-tighten the bolts.

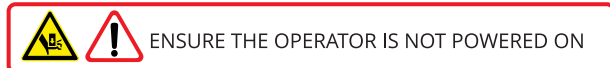

Whilst de-powered the operators arm can be moved which will rotate the operating assembly inside.

- Move the arm til the M12 bolt is accessible from the top, loosen the M12 bolt but do not remove.
- Rest the arm in the naturally occurring closed position.
- Loosen the M6 bolts but do not remove.
- Adjust the arm to the correct horizontal Level.
- Tighten the M6 bolts.
- Tighten the M12 bolt.

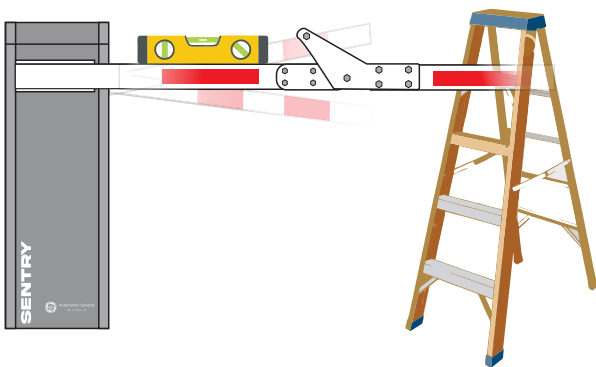

M6 Allen Bolt  
Aligns Main Link to Main Shaft  
(Breaker Bar Required)

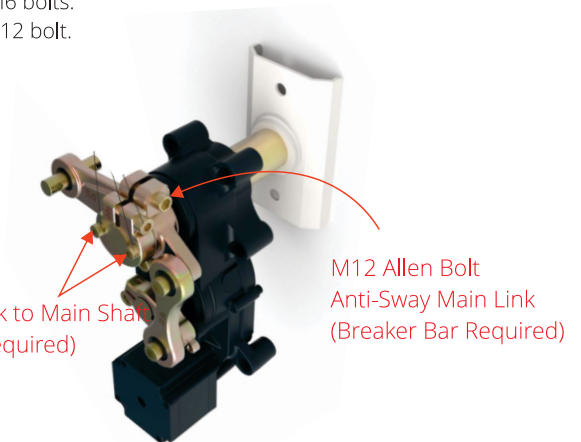

5

"Left" Side Configuration Knockouts

"Right" Side Configuration Knockouts

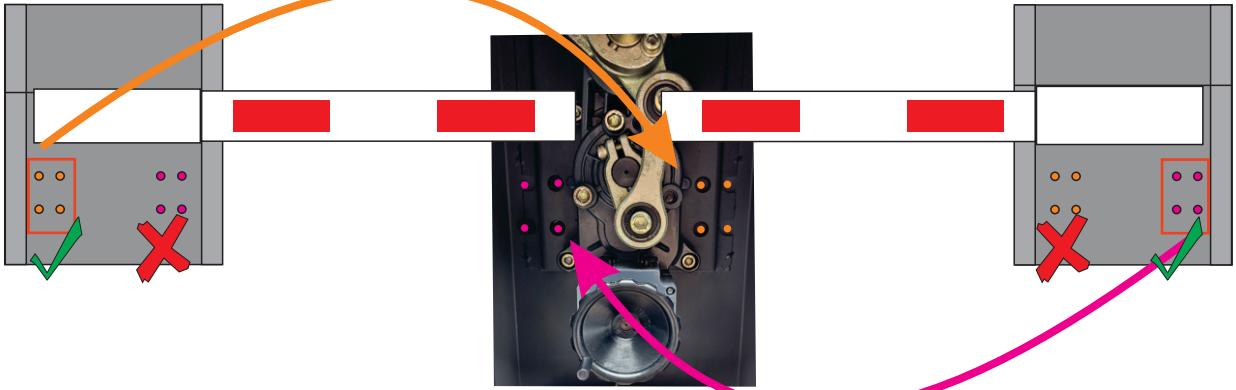

Locate the knockouts specifically according to the correct side configuration, they may be hard to visually see and you will need to look closely for there round outline.

Punch in the knockouts with a centre punch or a small screwdriver.

6

Fix the bracket in place using the supplied Allen Bolts, Medium strength (Blue) thread lock should be applied ideally.

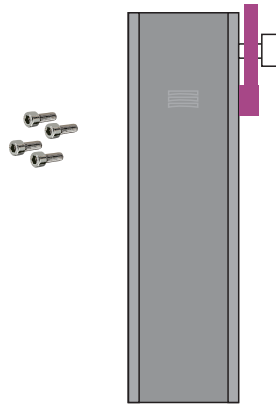

7

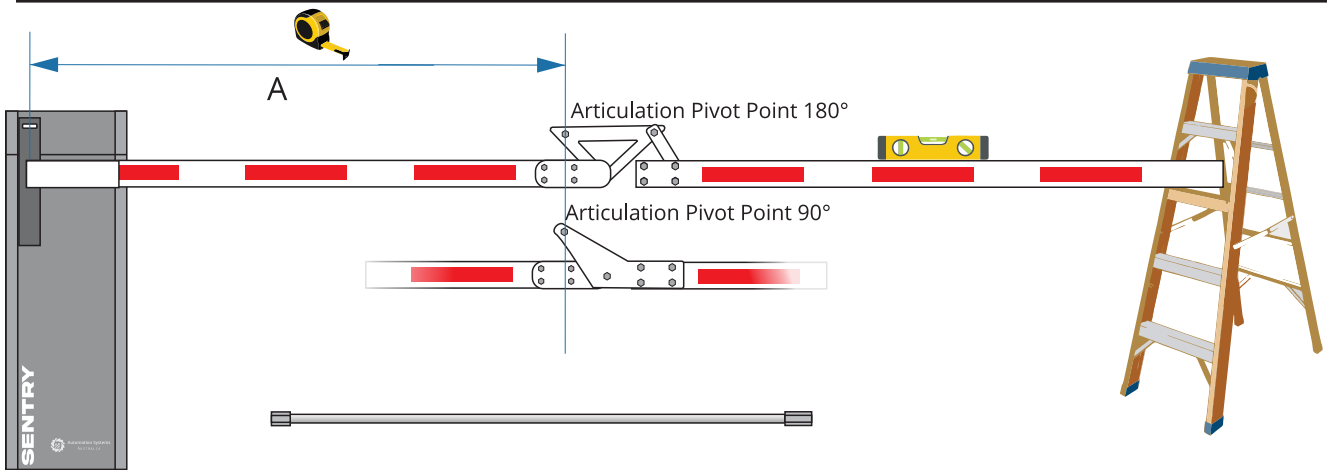

Ensure the trailing arm is level, now measure the "A" distance from the articulation pivot point to the centre of the bracket on the boom gate operator.

With the "A" measurement reduce 90mm from it, this is the threaded rods length to suit your installation. The 90mm that was reduced from the initial measurement is take up by the eyelets and the adjuster nut.

The cover rod should be 110mm shorter than measurement "A" , this will allow for adjustment.

# 8

Install the rod assembly and tune the trailing arm to be level. Adjust the main turning in and out of the adjuster nut whilst ensuring the spherical bearings remain threaded and seated sufficiently. Fine tune the alignment using the long and short grub screws. Once complete lock all joints with the nuts on the threaded rod.

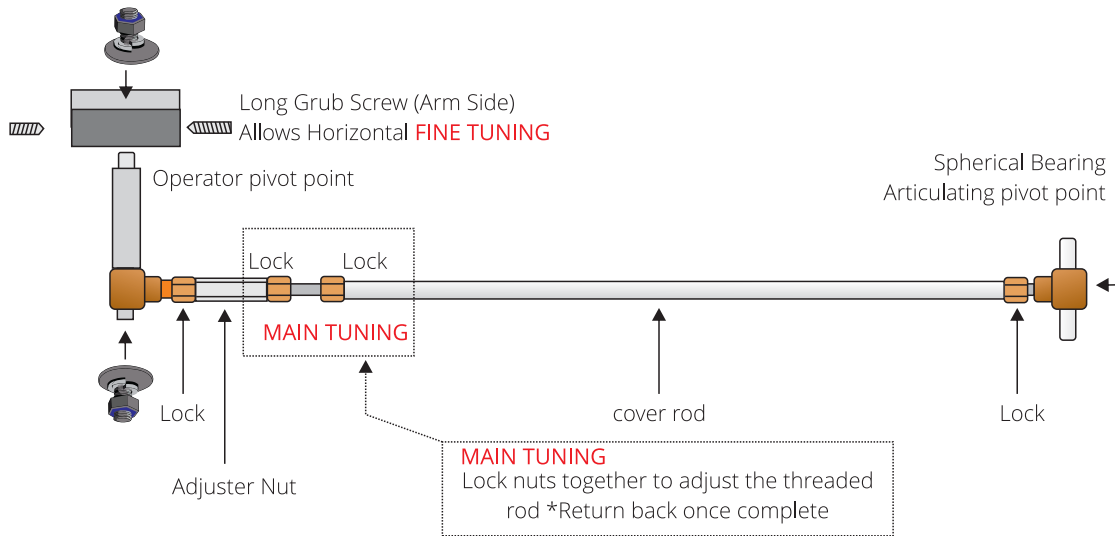

# 9

Balancing springs are pre-installed based on the chosen size during purchasing, they will need adjustment based on the observation of the arm. Each time the system is turned ON it will slowly OPEN (UP) and CLOSE (DOWN) the boom arm.



NEVER ADJUST WHILST THE OPERATOR IS IN MOTION (Turn the power OFF prior to each adjustment)

NEVER ADJUST WHILST THE SPRING IS IN ITS EXPANDED STATE

Always Loosen the locking nut prior to adjusting, Always tighten the locking nut prior to powering ON.

Turning ON the power to the system will trigger an automatic motion of UP and DOWN, this can be used to observe the operation in a slow speed. Any triggers by access control after the first motion will run the system at a normal speed.

You can power OFF when the arm is down and then power back on to observe the slow motion again.

Always power OFF the system between adjustments., NEVER power OFF mid cycle as the arm will come racing down without a powered motor.

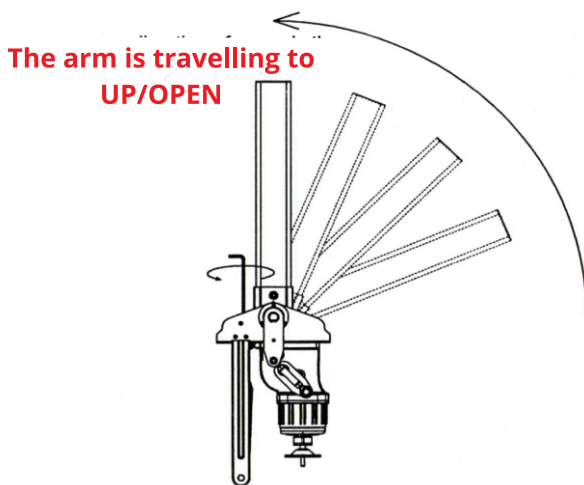

The arm shakes when it has reached/reaching the UP position this indicates the pre-load is too high, decrease the pre-load by adjusting anti-clockwise to loosen.

DUAL SPRINGS, ALWAYS ADJUST TOGETHER EQUALLY

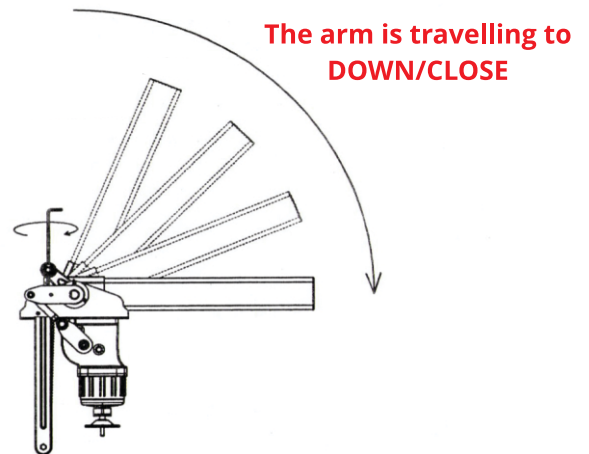

The arm shakes when it has reached/reaching the DOWN position this indicates the pre-load is too low, increase the pre-load by adjusting clockwise to loosen.

DUAL SPRINGS, ALWAYS ADJUST TOGETHER EQUALLY

# Controller Layout

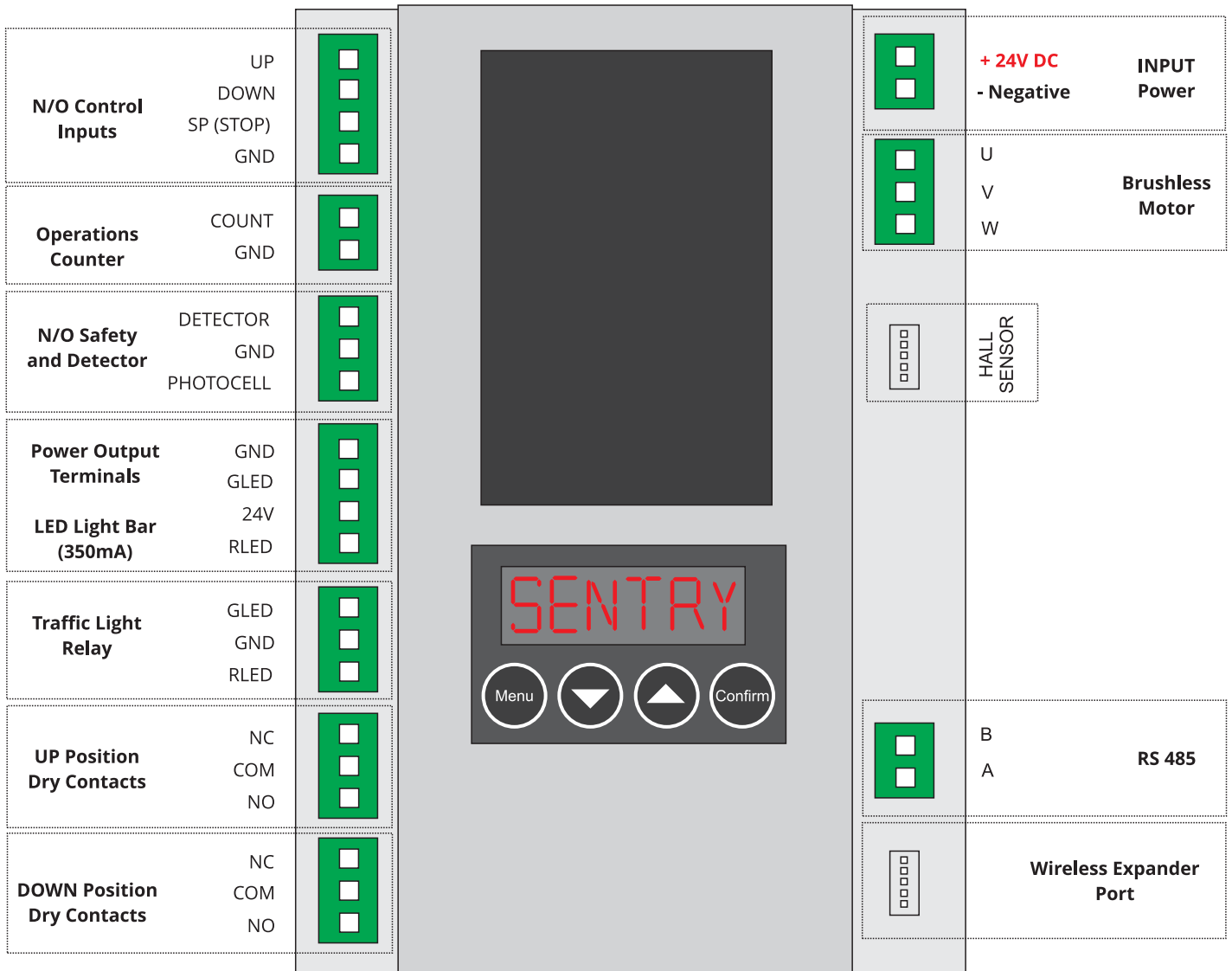

# Internal Power Supply

The transformer on a mains powered system is the primary source of power, it takes the high voltage input and transforms to low voltage which is connected to the controller.

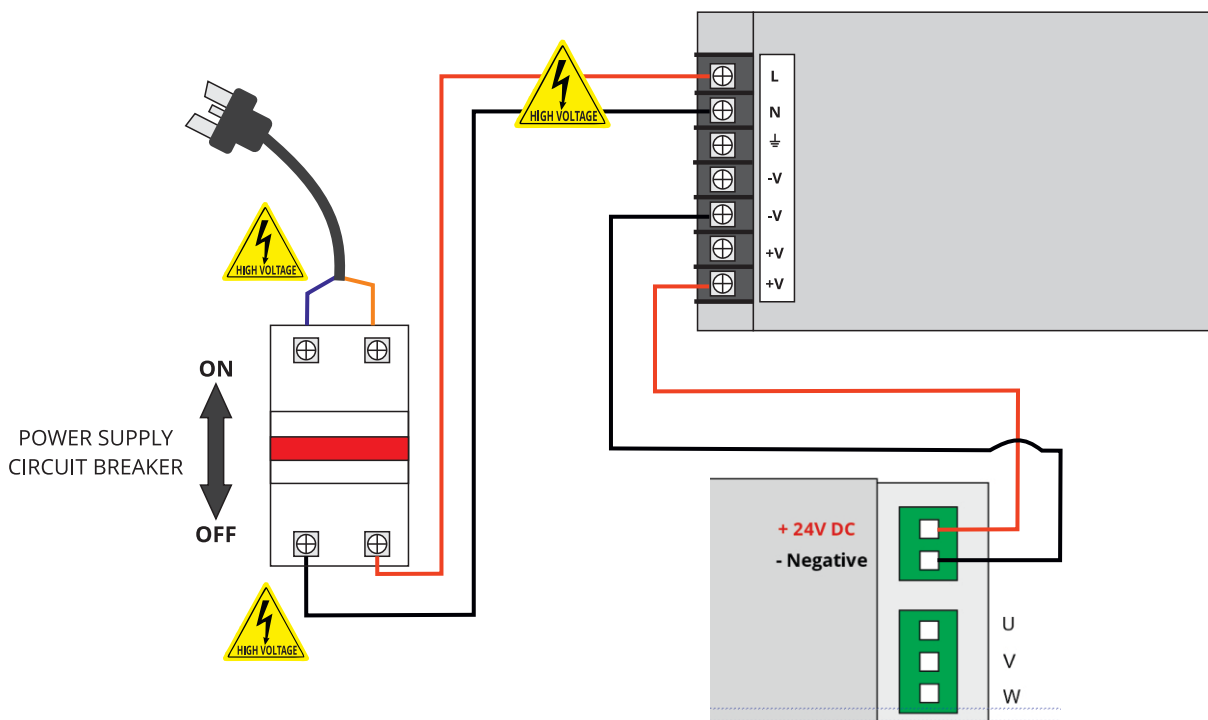

# Standalone Solar System Connection

A standalone solar system is a totally off grid solution used for green energy initiatives or simply when its not possible to run power to the gate system. To conserve power constant power draw devices such as wired keypads and magnetic locks are not to be used. The alternatives are wireless keypads (use there own batteries) and electric locks (only powered for two seconds per cycle).

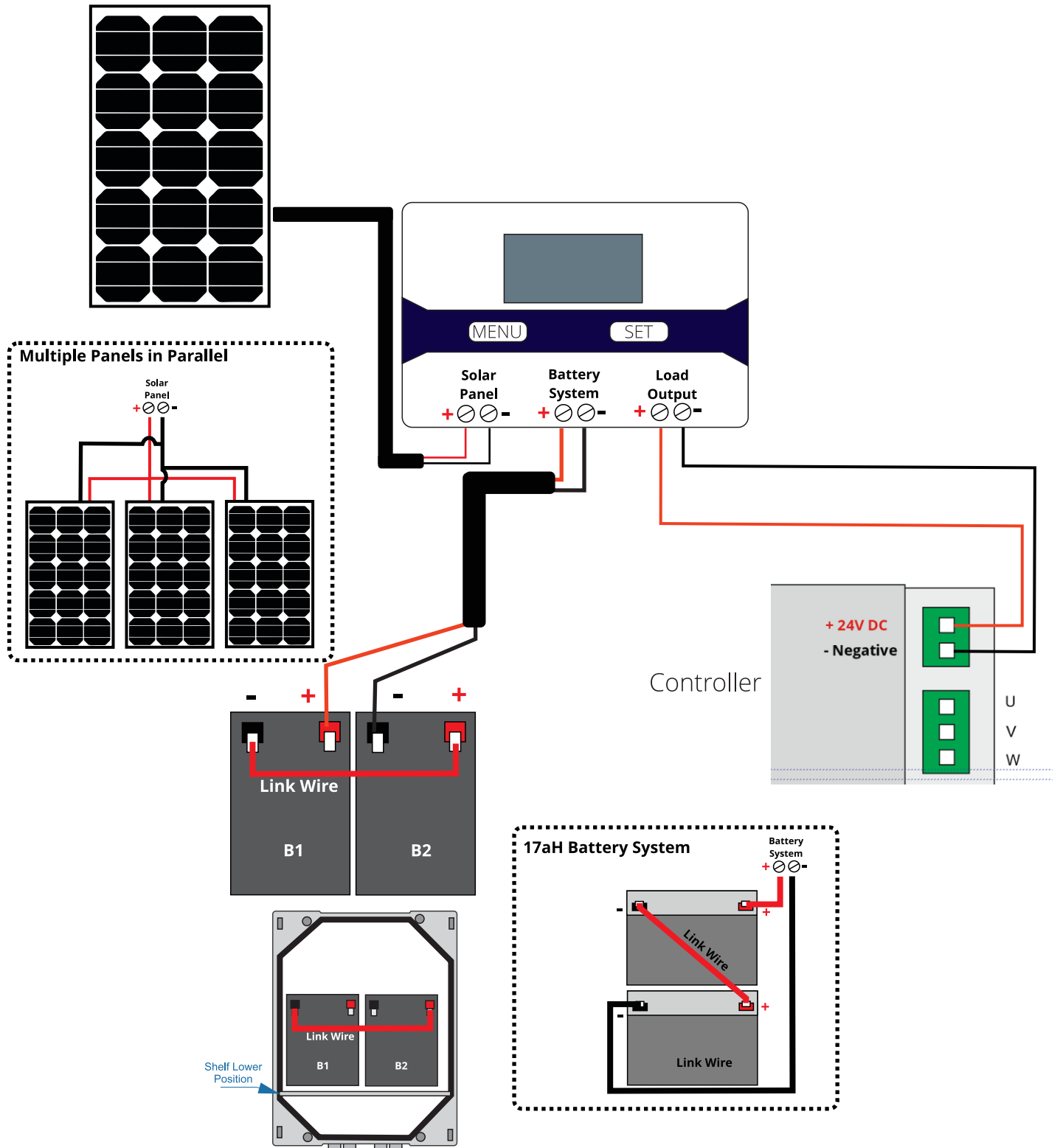

1. A solar panel CANNOT be installed under a tree, it requires sun to charge and maintain the batteries.

2. A solar system is often maintenance free BUT the batteries may require a external charge in the winter months due to lack of sun (rare).

3. Constantly powered accessories such as wired keypads will increase the standby current draw, solar panel or battery upgrades may be required if insufficient sun collection is not achieved.

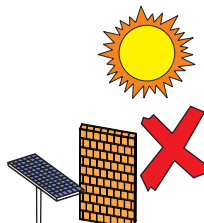
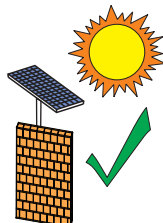
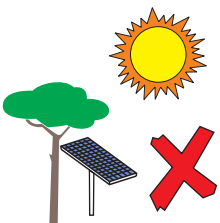



## Programming a remote:

Press the button on the wireless expander for two seconds, then press and HOLD the UP button on the remote .

## To Clear the memory:

Press and HOLD the button on the wireless expander for 10 seconds.

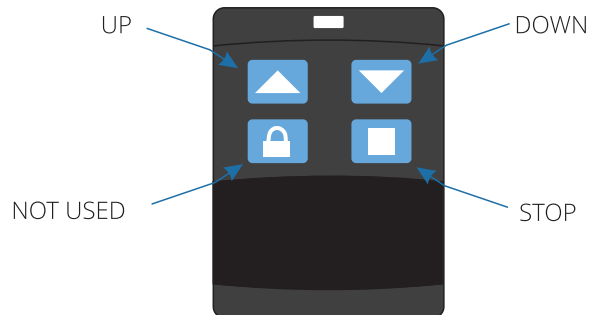
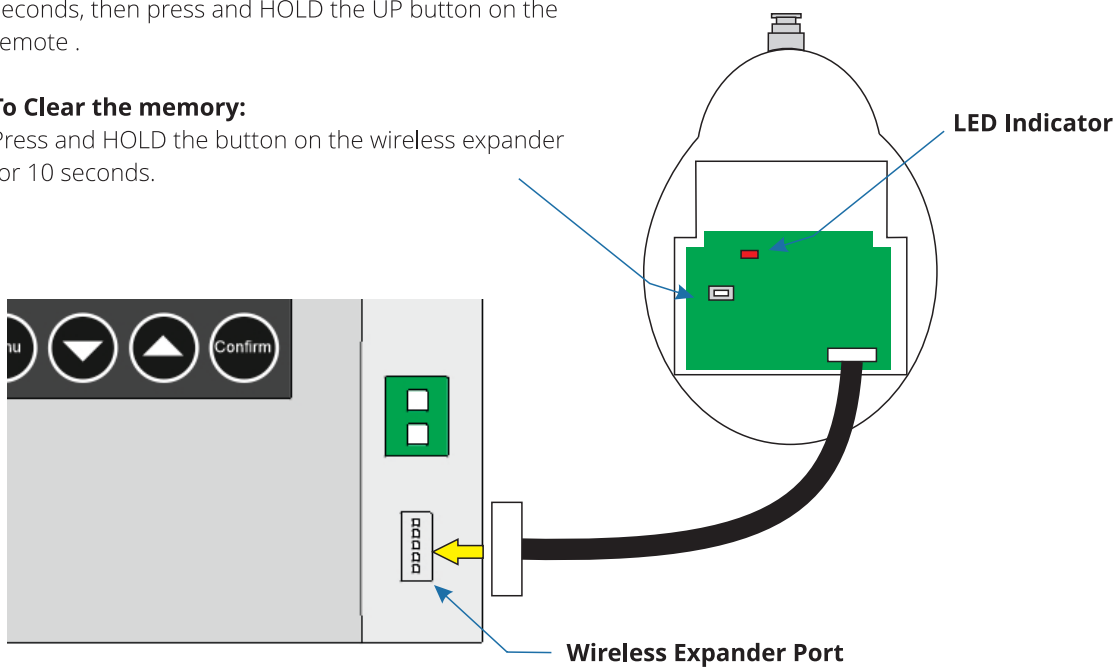

# DUKIE X and DUKIE XR Photocell/Retro Reflective Sensor as a SAFETY DEVICE

## Typical Arangement

SEE NEXT PAGE ON SENSORS AS A DETECTOR

Safety Sensors are a necessity when automating, they provide an additional layer of safety by infrared beam across the driveway.

The photocell terminal is used as the primary photocell connection which will revert the arm back to open when an obstacle is detected during close. If an obstacle is present before a close command then it will prevent closure til the obstacle is clear.

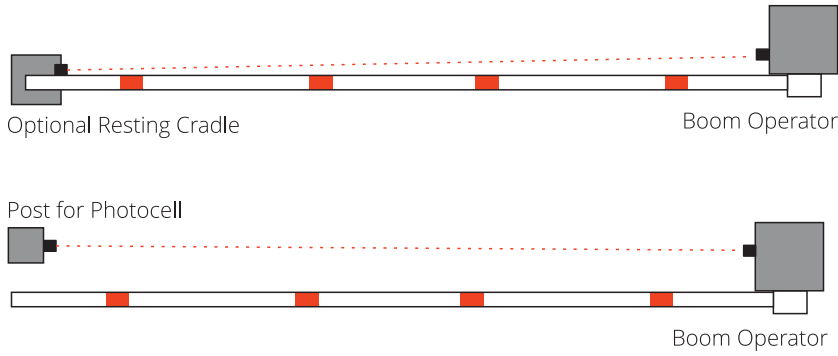

## Dukie X

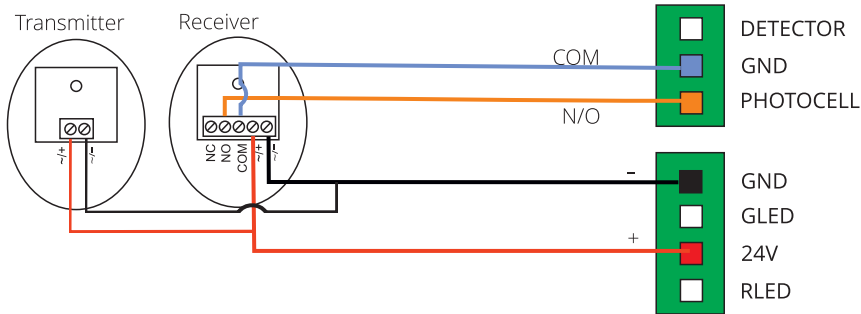

## Dukie XR

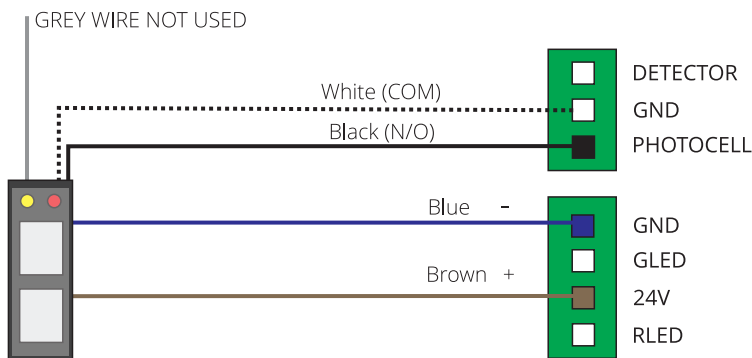

Special Detector Mode

SEE PREVIOUS PAGE ON SENSORS AS A SAFETY DEVICE

An additional set of sensors installed just past the gates open position. Ideal for scenarios requiring a command to close after the vehicle has passed through.

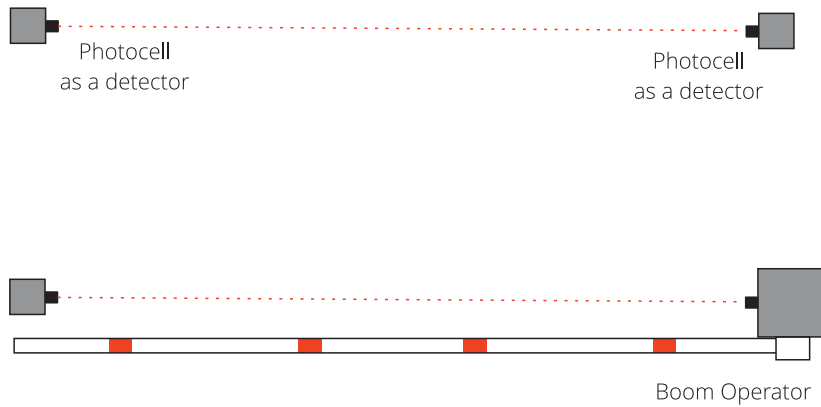

Dukie X

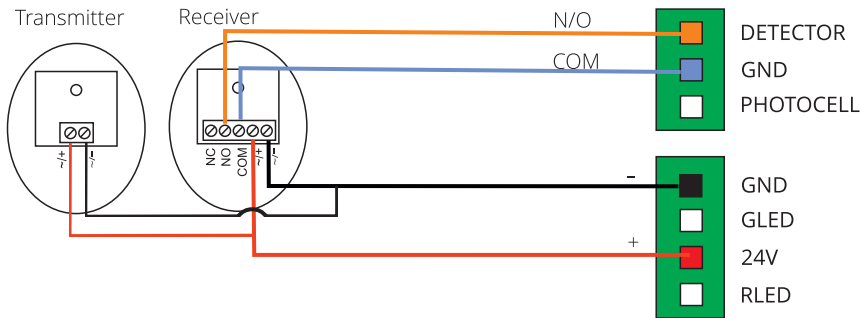

Dukie XR

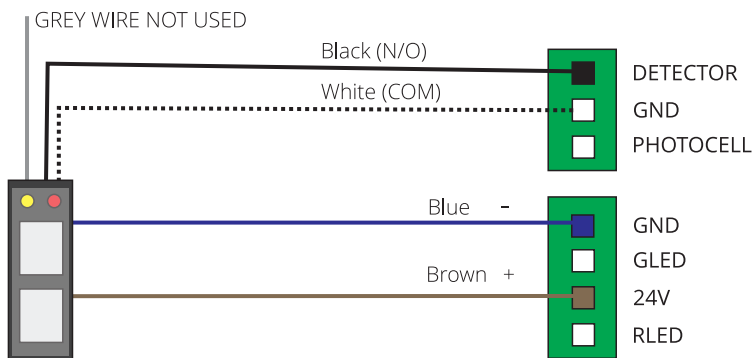

## Traffic Light Output

The traffic light output can be used to power a Green-Red traffic light for signalling traffic. The traffic light output RLED will always be ON to indicate RED/STOP when the boom gate is CLOSED or OPENING, when open the GLED output will be ON to Indicate Green to go.

NOT THIS TERMINAL

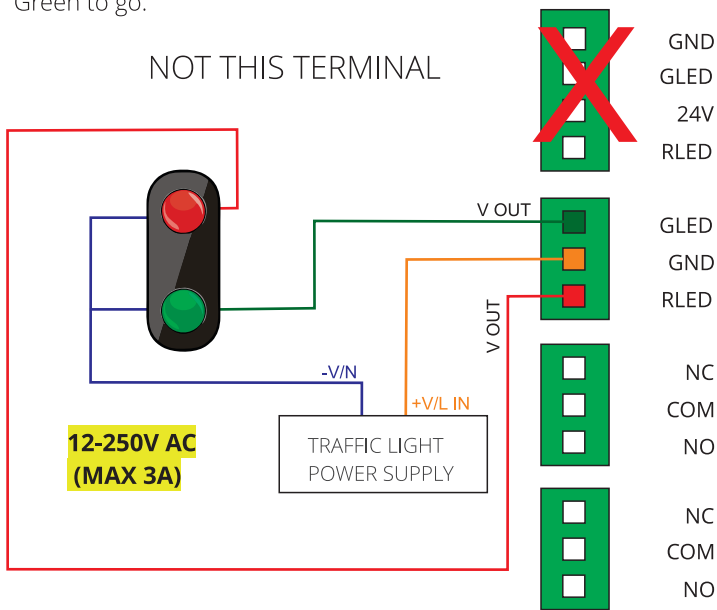

## Open and Closed Position Relays

The open and closed individual position relays can be used to toggle Alarms, sirens, buzzers, lighting systems, counters and numerous other integrations. They will provide a latching circuit of either N/O or N/C as required by the application.

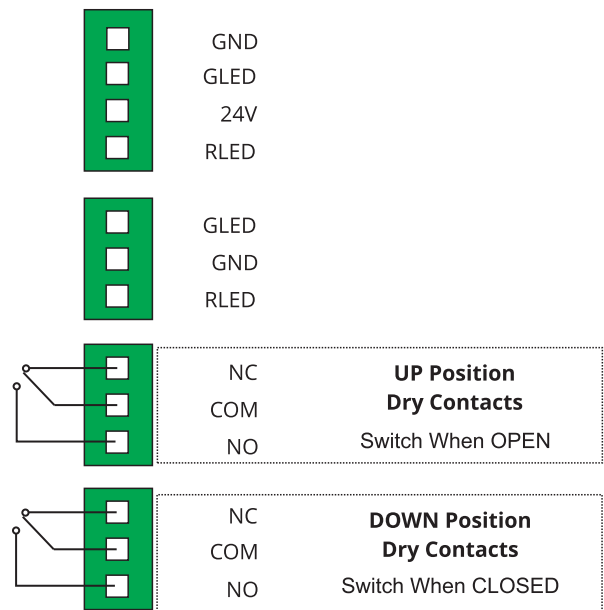

## Emergency Stop Button

An emergency stop button is used typically if the system is in a manned operation such as a security office or gate house OR such applications where an internal barrier is automated.

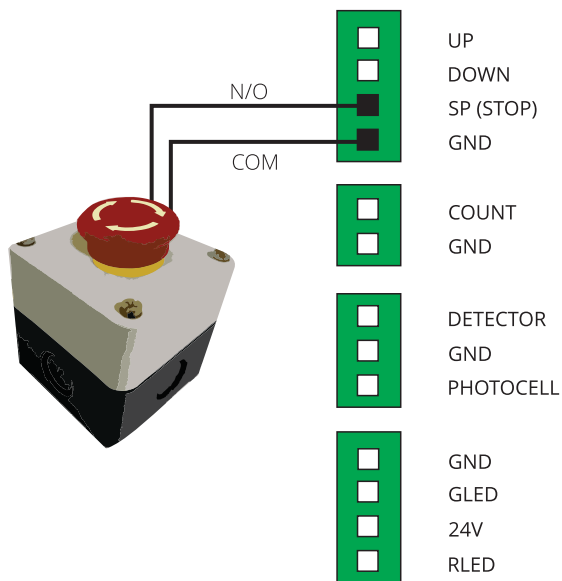

## Tekno Wi-Fi APP Switch

The Tekno Wi-Fi App Switch integrates into the system allowing for operation by APP anywhere in the world, the Tekno module requires good 2.4GHZ connection to the Wi-Fi of the premises.

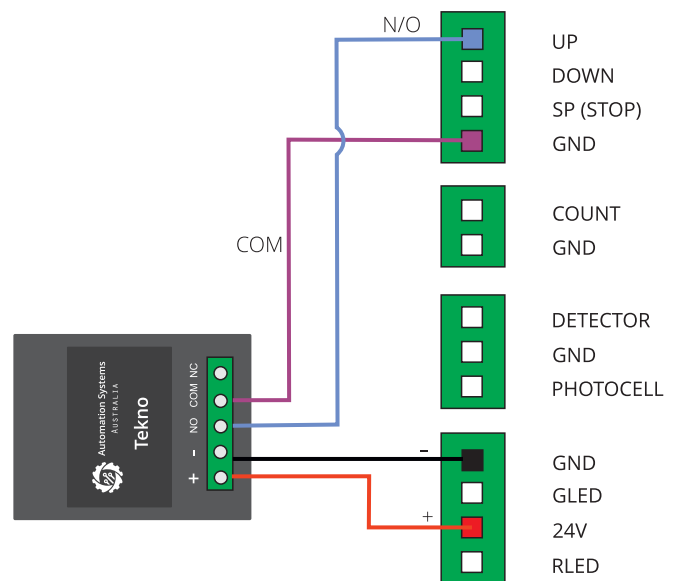

# Loop Detector

A loop detector can be used to command an OPEN or a CLOSE operation when detecting a vehicle.

## Automatic Opening

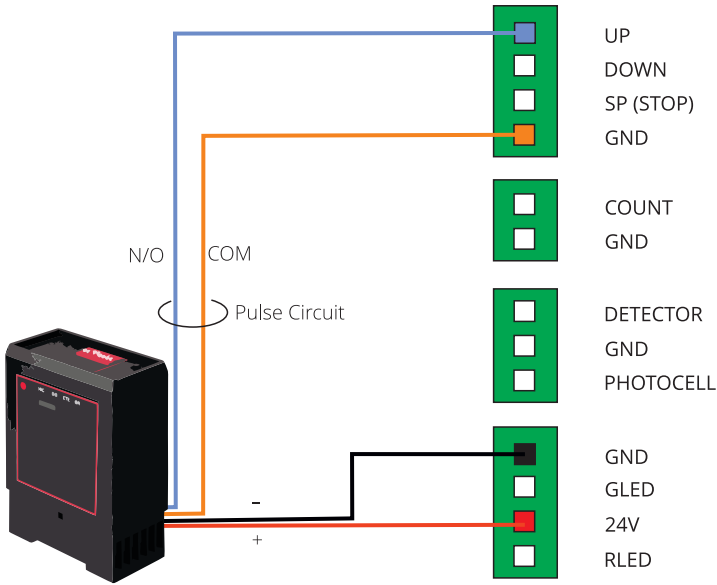

## As a Safety Device

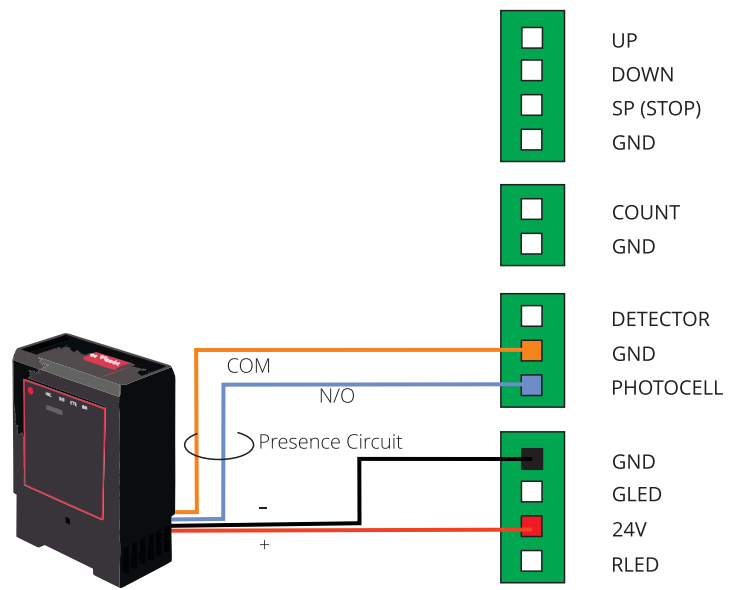

## To close automatically after pass through

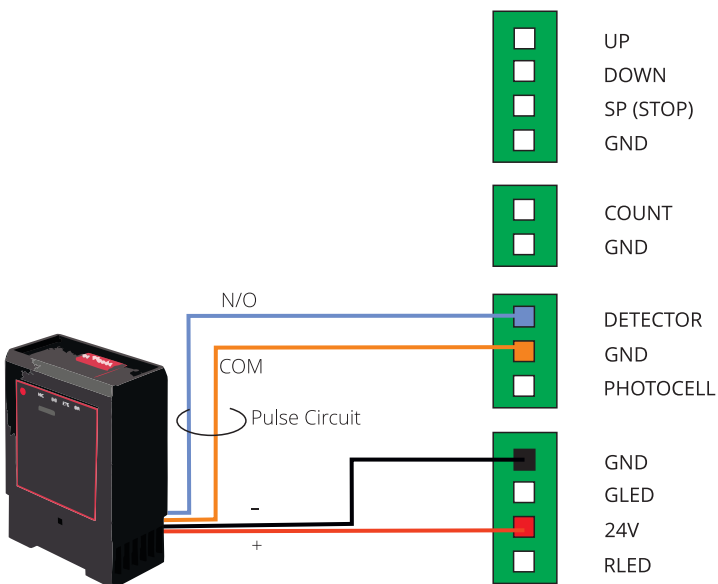

## Wired Keypad

A wired keypad has little to no maintenance required as its power feed is supplied by the system through wiring.

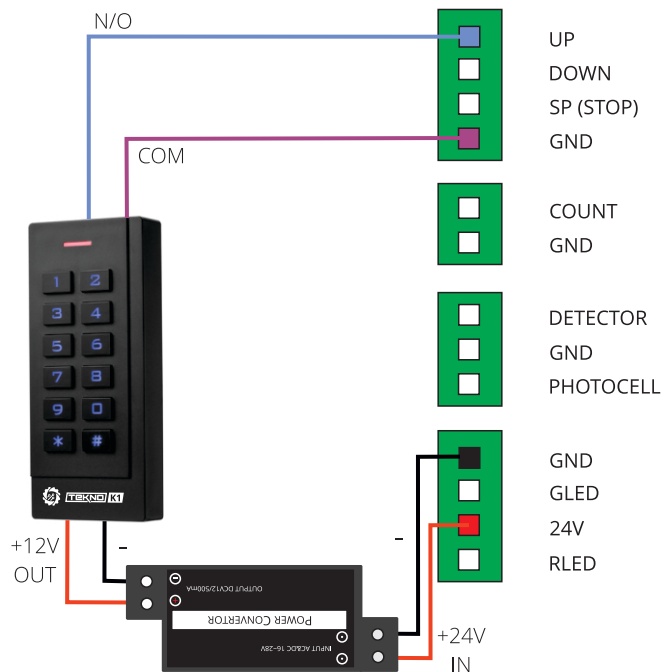

## Push Button

A push button can be used to operate the boom gate simply by pressing the button. A button can be installed for UP, DOWN or BOTH.

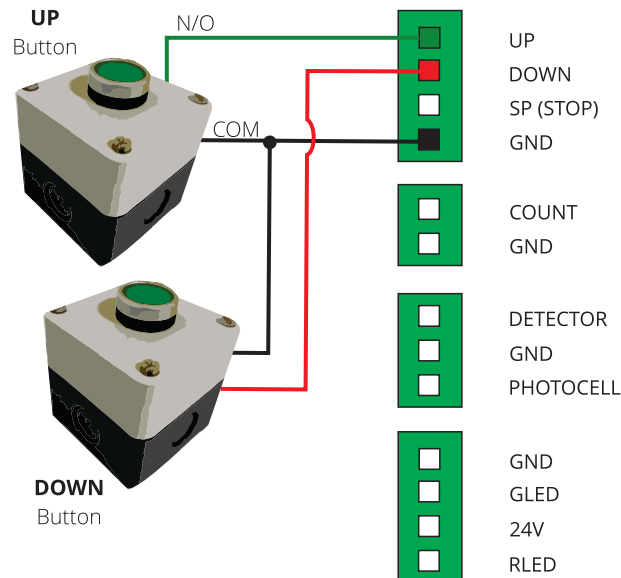

## Tekno 4 GSM Intercom

The Tekno 4 GSM intercom allows totally wireless TWO WAY communication to any user, anywhere in the world using the mobile network. It allows for the automatic gate operation by pressing \* during a call or by sending an SMS command at any time.

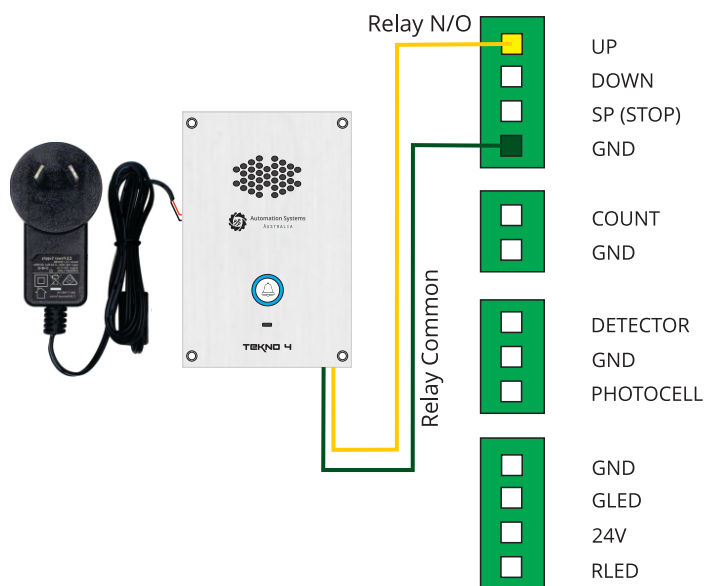

## Digital Weekly Timer (24 Volt Version)

The boom gate can be set to open at a certain time (and hold open), then close also at a set time. Multiple times can be programmed for all 7 days of the week selectively.

All other operations (outside of weekly time, eg. After Hours) by other access control devices such as a keypad will result in an automatic closing after the set control board automatic closing timer.

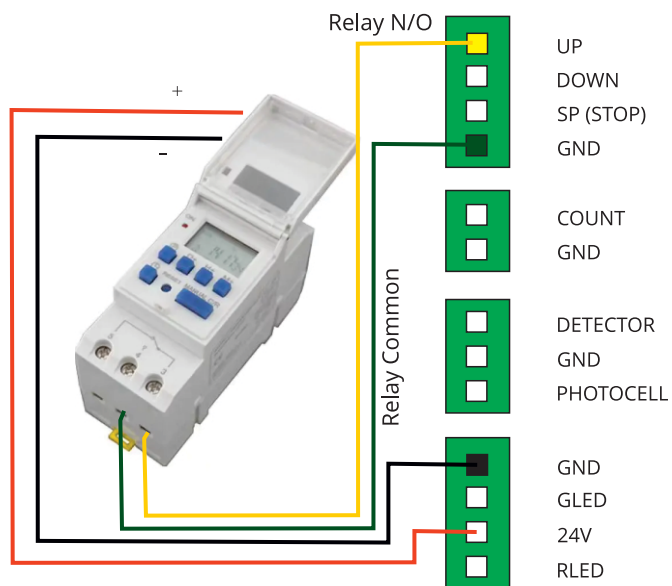

### TURN OFF THE SYSTEM BUZZER

H00-36

On Board Beeper

0=OFF (Use this for weekly timers)

## System Settings

### H00-00

The opening speed adjustment (Default is 40)  
Adjustable from 25-95

### H00-01

The closing speed adjustment (Default is 40)  
Adjustable from 25-95

### H00-02

Slow speed OPEN position angle (Default is 35)  
Adjustable from 5-40

### H00-03

Slow speed CLOSE position angle (Default is 35)  
Adjustable from 5-40

### H00-06

DECREASE the angle adjustment of the open position (Default is 1)  
Adjustable from 1° to 20°

### H00-07

DECREASE the angle adjustment of the close position (Default is 1)  
Adjustable from 1° to 20°

### H00-08

Over current/Auto Reverse Sensitivity (Default is 10)  
Adjustable from 7-13

### H00-09

Automatic closing timer adjustment (Default is 0=OFF)  
Adjustable from 0 (OFF) the 1 second to a maximum of 90 seconds

### H00-21

Factory Reset, cycle to 3 and confirm then return to 0 and confirm

### H00-24

Stop button function  
0= Functions as a total STOP  
1= If closing and STOP is activated it will reverse to the OPEN position

### H00-28

LED Light Output  
0= Normal Static Illumination  
1= Flashing  
2= Green will illuminate from when the arm reaches 45° position

### H00-36

On Board Beeper  
0=OFF (Use this for weekly timers)  
1= On

## Error Definitions

EFF01 Hall Sensor Error, Check the motor wiring  
EFF02 Under Voltage Error, the voltage is below 22V  
EFF03 Over Current Protection, High load reached, problem with controller, wiring is incorrect

## Warranty Terms and Conditions

The product is warranted for a period of twelve months (one year) from the date of purchase, unless expressly specified as extended warranty (extension to the warranty period). The product is to be installed for its intended purpose and for normal use as outlined within the installation manual, the product warranty is exclusively for defects in manufacturing and manufacturing workmanship. It does not cover out of guidelines use, natural or other disasters, abnormal weather conditions, damage incurred in shipping or handling, damage caused by disaster such as fire, flood, wind, earthquake, lightning, excessive voltage, mechanical shock, water damage, damage caused by unauthorized attachment, alterations, modifications, or foreign objects, damage caused by peripherals (unless such peripherals were supplied by Automation Systems Australia), defects caused by failure to provide a suitable installation environment for the products, damage caused by usage of the products for purpose other than those for which it was designed, damage from improper maintenance, damage arising out of any other abuse, mishandling, and improper application of the products.

At its discretion Automation Systems Australia will require the item determined by the support staff to be returned to base in its original unmodified condition for a warranty inspection if within the warranty period. A return authorization "RA" number will be provided to be enclosed with the product in question. The warranty will not cover freight fees to base, customs fees or any labour costs at the installation site but will cover repair or replacement of the product as seen fit. Automation Systems Australia will cover the freight of the returned item to the original address if deemed as a warranty repair or replacement item. Any warranty repairs or replacements continue to carry through the remaining warranty period and do not extend or restart the period.

Under no circumstances shall Automation Systems Australia be liable for any special, incidental, or consequential damages based upon breach of warranty, breach of contract, negligence, strict liability, or any other legal theory. Such damages include, loss of profits, loss of the product or any associated equipment, cost of capital, cost of substitute or replacement equipment, facilities or services, down time, purchaser's time, the claims of third parties, including customers, and injury to property.

This warranty contains the entire warranty and shall be in lieu of any and all other warranties, whether expressed or implied (including all implied warranties of merchantability or fitness for a particular purpose). And of all other obligations or purporting to act on its behalf to modify or to change this warranty, nor to assume for it any other warranty or liability concerning this product.

Automation Systems Australia will at its option repair or replace out-of-warranty products at a determined cost which are returned to its base according to the following conditions. Anyone returning goods to Automation Systems Australia must first obtain an authorization number. Automation Systems Australia will not accept any shipment whatsoever for which prior authorization has not been obtained. Products which Automation Systems Australia determines to be repairable will be repaired and returned. A set fee which Automation Systems Australia has been predetermined and which may be revised from time to time will be charged for each unit repaired. Products which Automation Systems Australia determines not repairable will be replaced by the nearest equivalent product available at that time. The current market price for the replacement product will be charged for each replacement unit.