

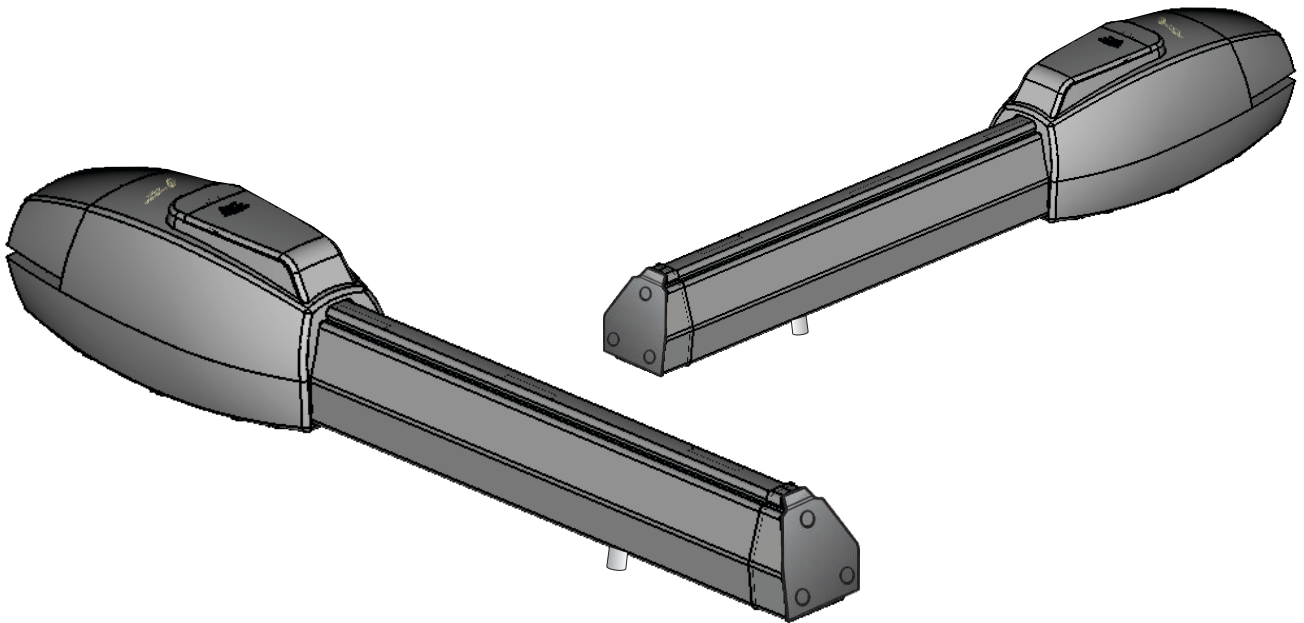

Automation Systems AUSTRALIA

BANDIT

24 Volt Discreet Drive Linear Actuators
with Limit Switches



Important!

Please read the manual carefully as it contains important points that need to be followed for a successful installation, we recommend reading all the preliminary information FIRST (page 1-3) then proceed to the relevant installation section and read in its entirety at least once before beginning the installation.

Pull To Open Installation (Gate opens TOWARDS the motor) begins Page 4

Push To Open Installation (Gate opens AWAY from the motor) begins Page 7

Specifications

Voltage	24V DC
Current	2.5A
Thrust	2300N
Gearing Structure	Metal
Case Material	Die-Cast Alloy
Limit Type	Normally Closed (N/C) in Series to Motor
Duty Cycle	90%
Working Temperature	-20°C to 60°C
IP Rating	IP54
Actuator Length	970mm
No Limit Stroke	390mm
Limit Stroke	370mm
Minimum Gate Length	800mm
Maximum Gate Length	3m

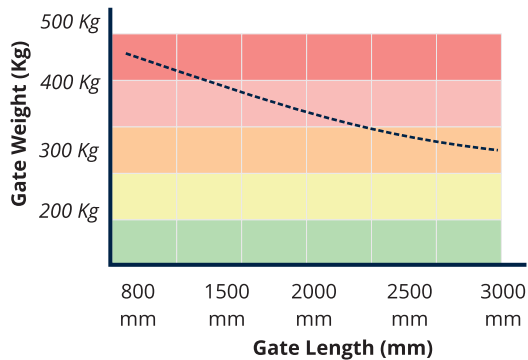

*Tested ratings are based on ball bearing hinges and no wind resistance

Dimensions

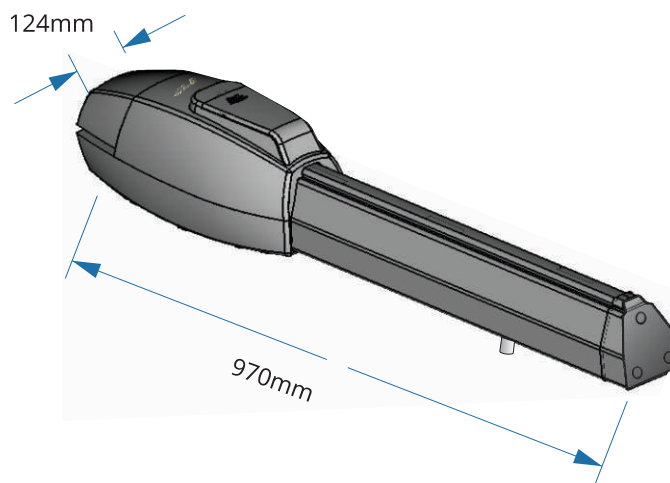

Actuator Overview

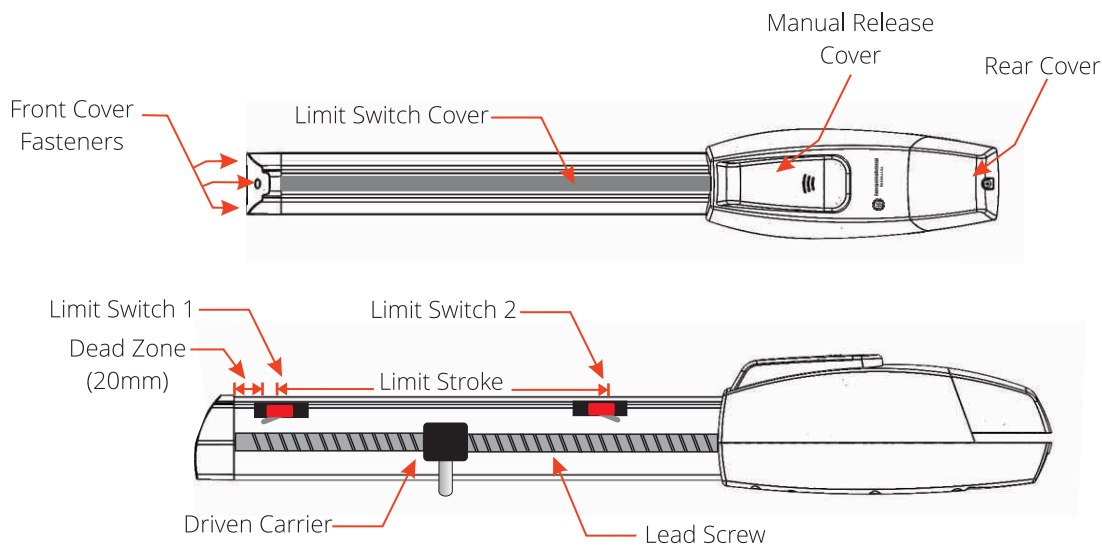

INTERNAL Limit Switch Controller (Pre-Wired)

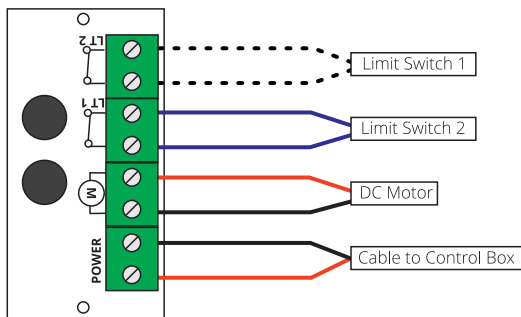

Installers Brief Checklist

- Ensure the gate(s) structure is rigid and does not flex
- Ensure you will be using an adequate fastening system to suit the structure and environment
- Ensure the gate(s) move freely and uniformly
- Ensure that a gate stop has/will be installed
- Ensure that the installation geometry can be adhered to
- Ensure that if any underground work is occurring you have followed the local regulations and checked with utilities providers
- Ensure the correct operator is to be installed based on size, weight, geometry and wind resistance
- Never supply mains power to a gate motor directly
- Never install if it will present a hazard or danger

Gate Stop and Actuator Placement

A Gate stop is strongly recommended to be installed as it will serve TWO purposes. Firstly it prevent the gate from over swinging OR being pulled/Pushed further past the closed point. Secondly it provides a place for the gate motor to push against before striking its limit switch, this allows for a better hold as the gearbox is in a loaded state and internal free play is minimal.

Ideally and recomeded (not mandatory) the gate stop should be within 400mm of the actuators mounting, meaning for double swing gate the actuators should be within 400mm from the ground level as there is typically a ground stop and for single gates within 400mm UP/DOWN from actuators gate rail.

Double Swing Gate Example

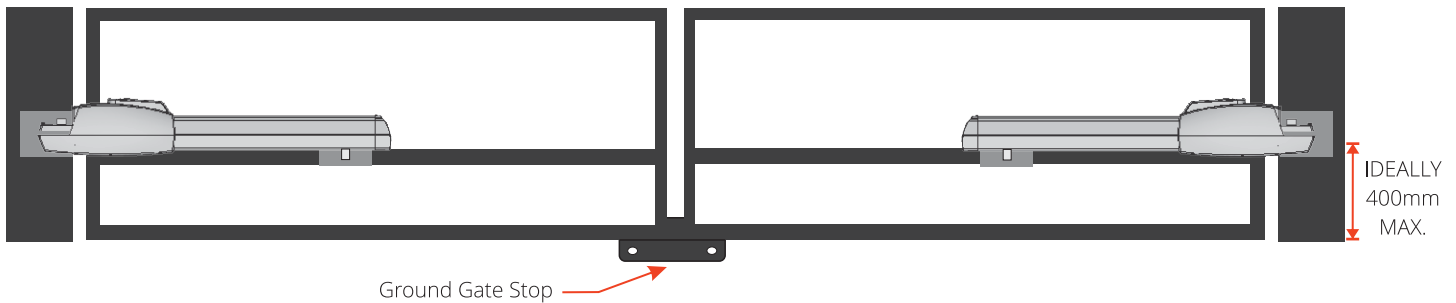

Single Swing Gate Example

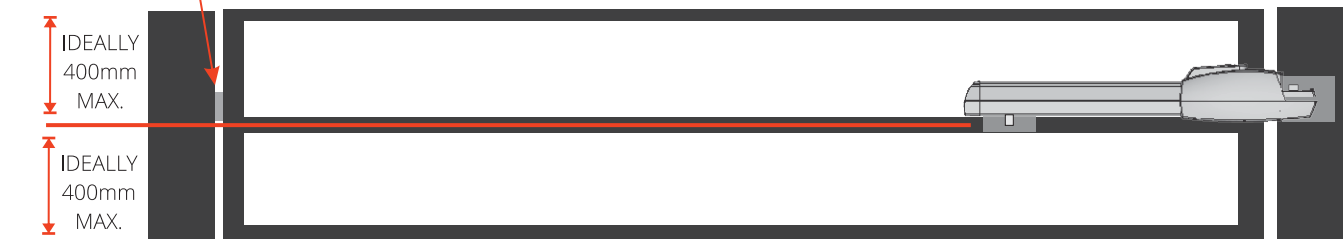

Manual Release (Clutch Override)

NOTE: If gate is under load (against a gate stop) move the gate back and forth as you turn the knob in Stage 2.

**UNLOCKING/
RELEASING**



Stage 1:
Insert Key and turn the
Key Cylinder 90°
to the UNLOCK Symbol

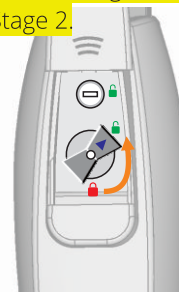

Stage 2:
Turn the KNOB 100°
to the UNLOCK Symbol

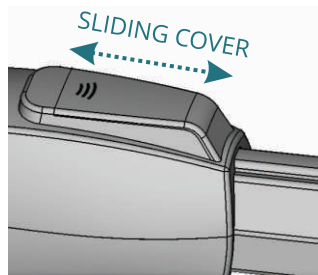

**LOCKING/
ENGAGING**

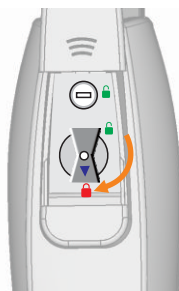

Stage 1:
Return the KNOB
to the LOCK Symbol



Stage 2:
Insert Key and turn the
Key Cylinder 90°

Post Bracket Sandwich Assembly

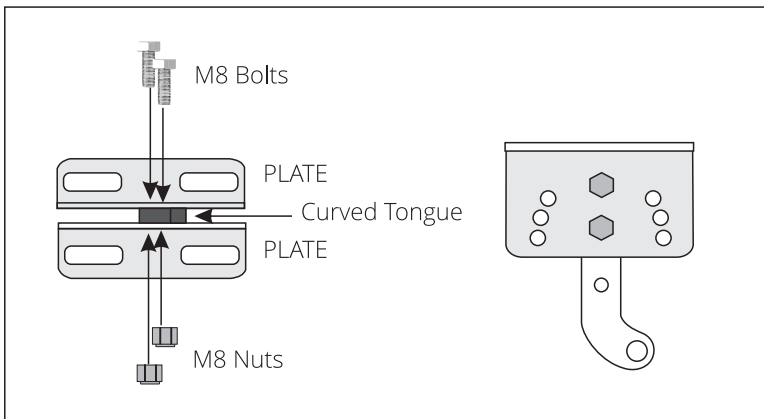
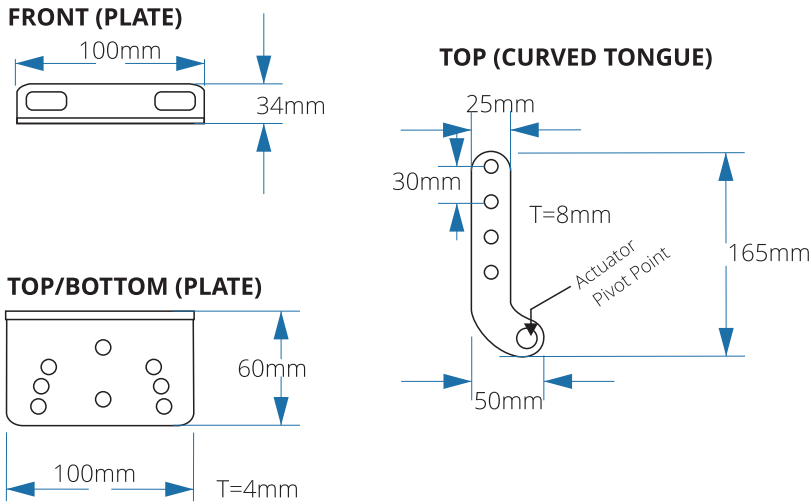

16 Different Assembly Options

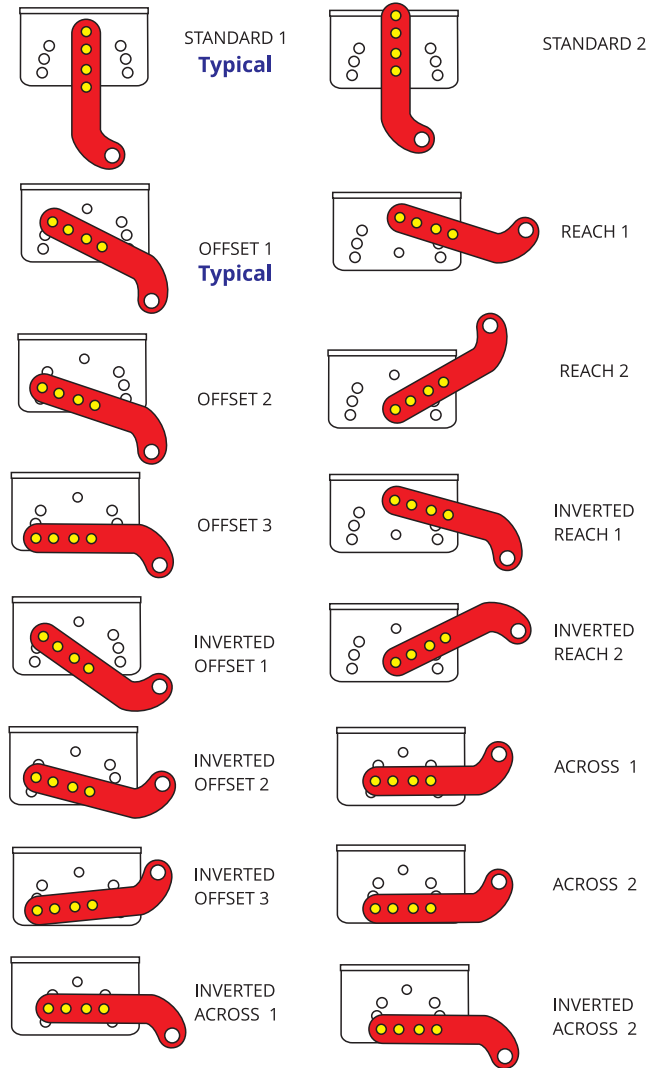

Gate Bracket

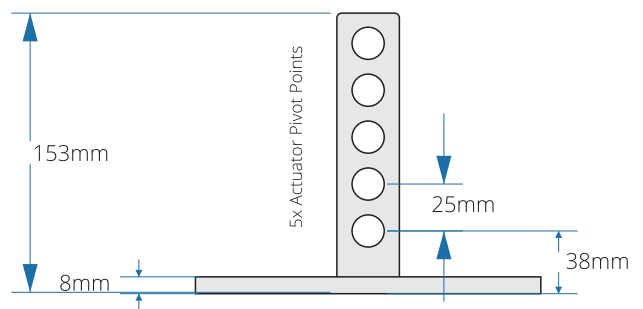
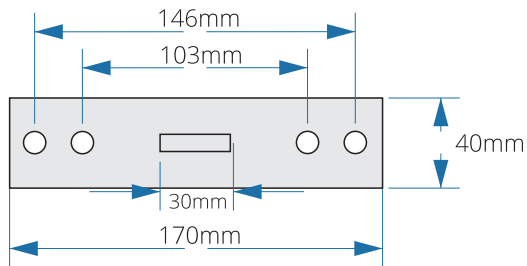

Round Timber Posts

Cut a Niche to allow for a flat installation surface.
 Use Coach Bolt or Coach Screws for Fixing

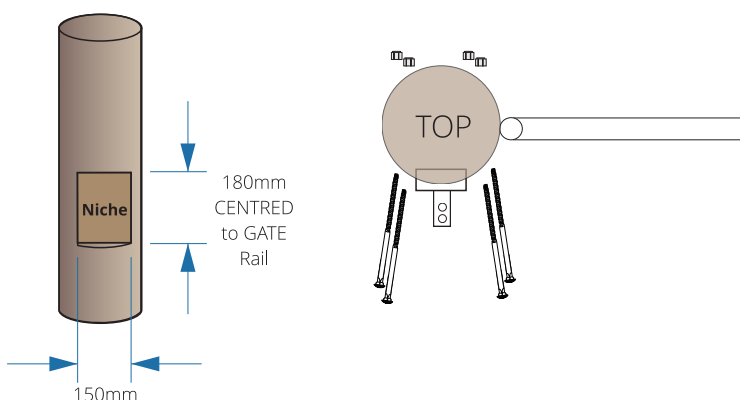

Farm Gates

Drill Holes according to correct placement of gate bracket.
 Use bolts and nut to install to the gate

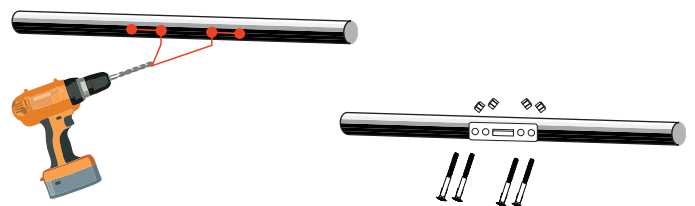

Pull To Open Installation (Gate opens TOWARDS the motor)

Step 1

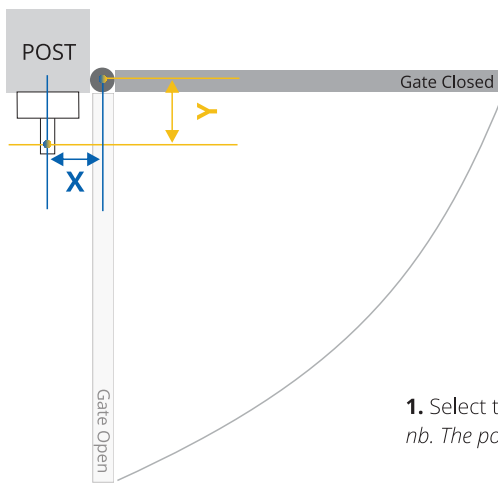

Centre of hinge to centre of pivot point on post bracket

	100mm	120mm	140mm	160mm	180mm	200mm	220mm
100mm	95°	105°	115°	120°	120°	120°	110°
120mm	95°	105°	110°	120°	120°	115°	105°
140mm	95°	100°	110°	115°	115°	110°	100°
160mm	95°	100°	105°	115°	110°	100°	95°
180mm	90°	100°	105°	110°	100°	90°	90°
200mm	90°	95°	100°	105°	95°		
220mm	90°	95°					

1. Select the best suited X and Y measurement to suit the installation
nb. The post bracket can be adjusted to reach the best Y measurement.

2. Attempt to keep X and Y to alike measurements (eg. X140mm should be Y140mm), up to 40mm in difference is allowed (eg. X140mm Y180mm)

Step 2

- A. Assemble the POST bracket to the best suited configuration.
- B. Draw a centre line from the gate rail to the post (gate rail centre).
- C. Draw an additional line on the post ABOVE the gate rail centre line by 55mm
- D. Install the actuator POST bracket to the post or wall according to the appropriate geometry WHILST Centred to the bracket centre line.

Adjust the bracket or cut the excess of the bracket now if necessary.

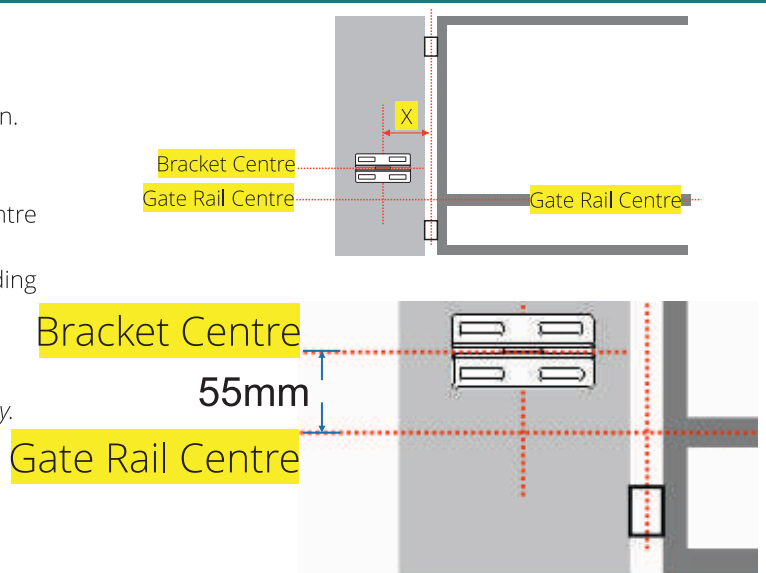

Step 3

With the gate CLOSED measure DIAGONALLY and MARK 710mm from the post bracket PIVOT POINT "X" to the gate, this is the centre line for the GATE bracket.

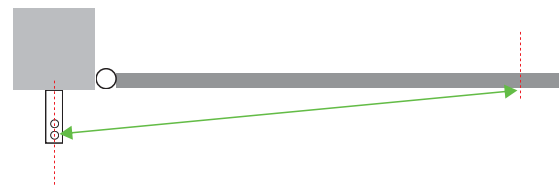

Step 4

Install the gate bracket to the post using the appropriate fasteners. Ensure the both the post and gate brackets are level, adjust if necessary.

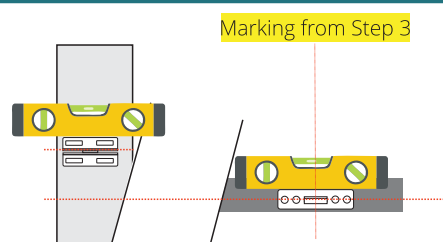

Step 5

Slide the actuator on to the post and gate brackets and fix in place using the supplied drop in pivot pin at the post bracket, for the gate bracket side use the supplied bolt and washer.

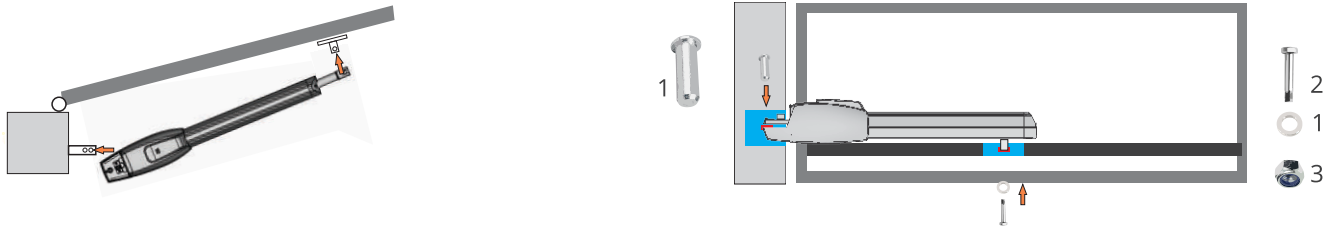

Step 6

Remove the 3 Front Cap retaining screws USING A SCREWDRIVER and pull the Front cap away from the actuator body as per illustration.

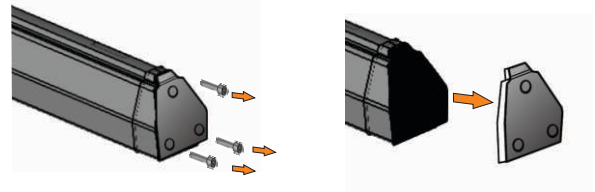

Step 7

Slide the limit switch cover away from the actuator and off the actuator by applying pressure with the palm of your hand and simultaneously pushing the cover.

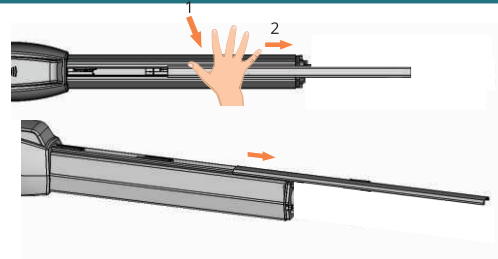

Step 8

Dis-engage the clutch by using the manual release, slowly close the gate observing the post bracket end ensure the following:

1. Gate can open and Close without touching the gate or post
2. The post bracket requires no trimming to allow the actuator to pivot.

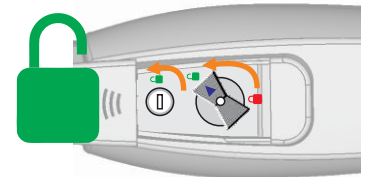

Step 9

Locate and observe the driven carrier in the inspection channel, it is black coloured and will move forwards/backwards as the gate is closed/opened. Move the gate to 45° open

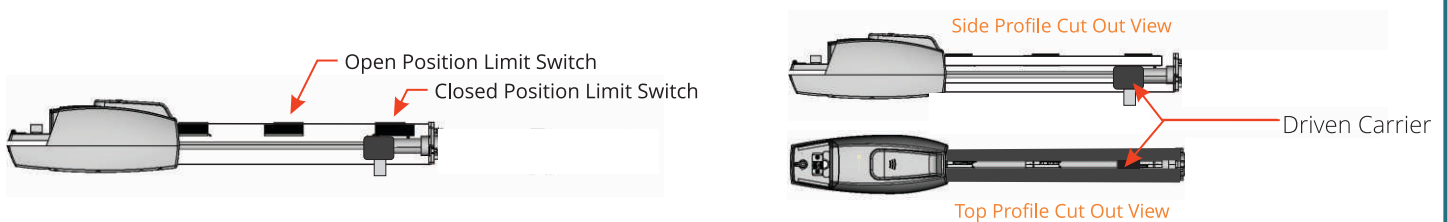

Step 10

Slowly close the gate and observe the driven carrier as it travels towards the closed position limit switch, once at the closed position move the limit switch slider forward/back as required til an audible mechanical click is heard from the limit switch being triggered.

If the limit switch is in the correct place but no click is heard ensure the limit switch is totally seated in the channel by pushing it down, its top should be flush with the top of the body.

Move the gate open 20°-30° and then back to close to ensure the limit switch is set correctly. Fine tune the adjustment as necessary.

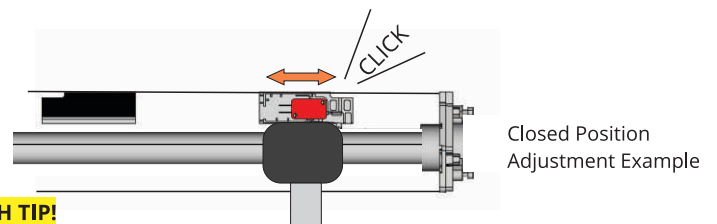

TECH TIP!

It is important to note that FOR THE BEST RESULTS the closed position limit switch should operate whilst the gate motor is pushing against the gate stop OR just after it has pushed against the gate stop. Best result are obtained by temporarily removing the gate stop and setting the limit switch point 10-20mm AFTER the gate stop allowing for a loaded gearbox (and reduced free play) when closed.

Step 11

Slowly open the gate and observe the driven limit switch striker nut as it travels towards the open position limit switch, once at the open position move the limit switch slider forward/back as required til an audible mechanical click is heard from the limit switch being triggered.

If the limit switch is in the correct place but no click is heard ensure the limit switch is totally seated in the channel by pushing it down, its top should be flush with the top of the body.

Move the gate closed 20°-30° and then back to open to ensure the limit switch is set correctly. Fine tune the adjustment as necessary.

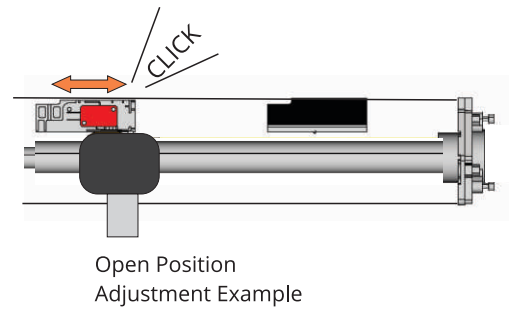

DOUBLE GATES: REPEAT ALL STEPS FOR THE SECOND MOTOR

Step 12

Follow the illustration bellow for the connection to the Premier 24 Swing Gate Controller paying attention to the **Motor 2 connection being the master gate** and Motor 1 Connection being the Second Motor for Double Gates.

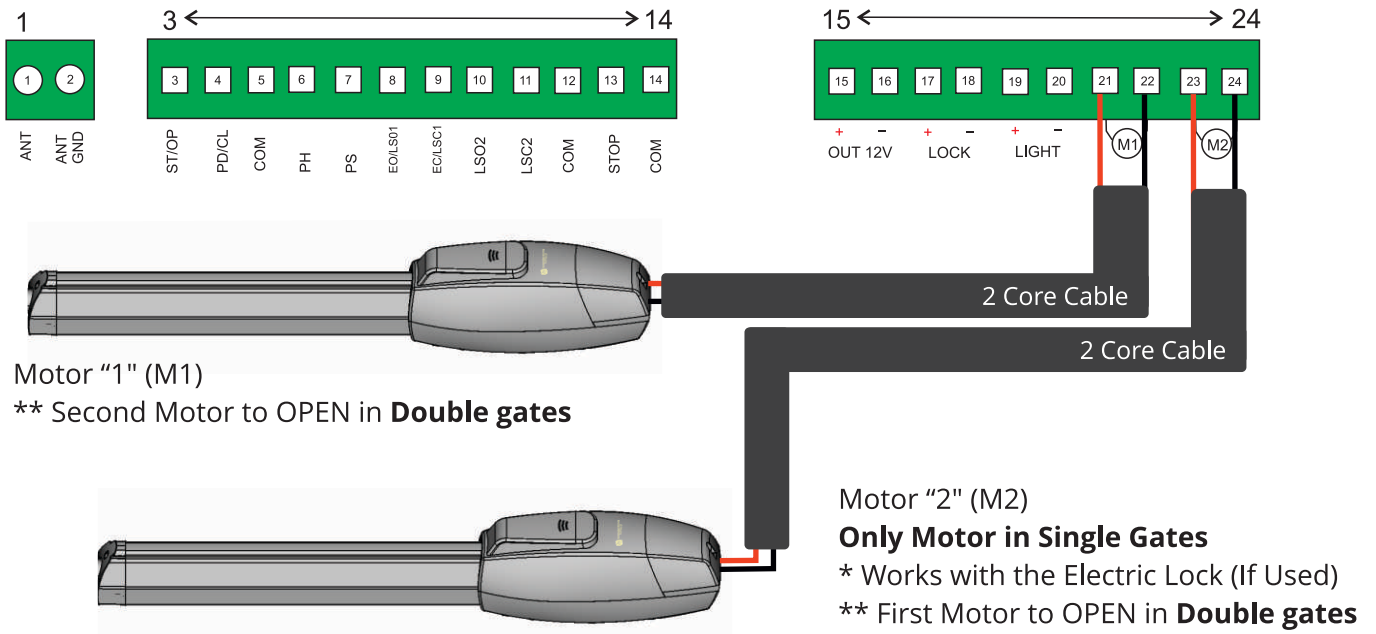

Step 13

Proceed to motor test section (Page 10)

AFTER MOTOR TEST

Re-install the limit switch cover, the small hole faces the actuator main body and will slide below the body when totally installed.

Install the front cover using a screw driver (do not use any impact drivers or electric drills)



Push To Open Installation (Gate opens AWAY from the motor)

Step 1

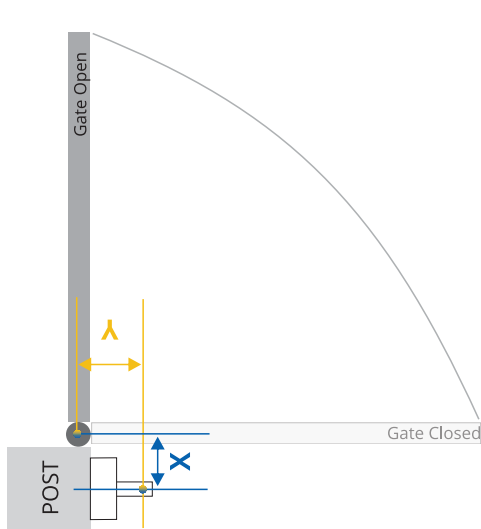

Centre of hinge to centre of pivot point on post bracket

	100mm	120mm	140mm	160mm	180mm	200mm	220mm
100mm	95°	105°	115°	120°	120°	120°	110°
120mm	95°	105°	110°	120°	120°	115°	105°
140mm	95°	100°	110°	115°	115°	110°	100°
160mm	95°	100°	105°	115°	110°	100°	95°
180mm	90°	100°	105°	110°	100°	90°	90°
200mm	90°	95°	100°	105°	95°		
220mm	90°	95°					

1. Select the best suited X and Y measurement to suit the installation
nb. The post bracket can be adjusted to reach the best Y measurement.
2. Attempt to keep X and Y to alike measurements (eg. X140mm should be Y140mm), up to 40mm in difference is allowed (eg. X140mm Y180mm)

Step 2

- A. Assemble the POST bracket to the best suited configuration.
- B. Draw a centre line from the gate rail to the post (gate rail centre).
- C. Draw an additional line on the post ABOVE the gate rail centre line by 30mm
- D. Install the actuator POST bracket to the post or wall according to the appropriate geometry WHILST Centred to the gate rail.

Adjust the bracket or cut the excess of the bracket now if necessary.

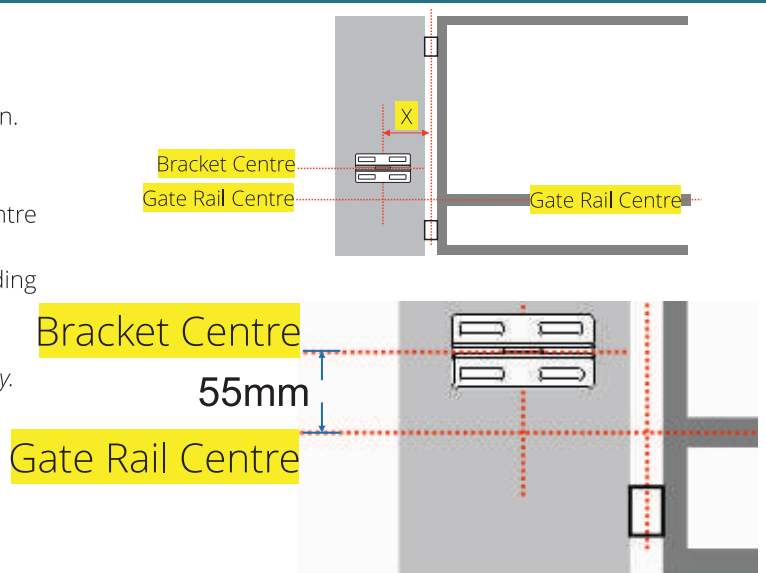

Step 3

With the gate OPEN measure DIAGONALLY and MARK 210mm from the post bracket PIVOT POINT "X" to the gate, this is the centre line for the GATE bracket.

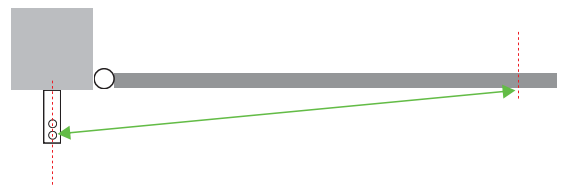

Step 4

Install the gate bracket to the post using the appropriate fasteners. Ensure the both the post and gate brackets are level, adjust if necessary.

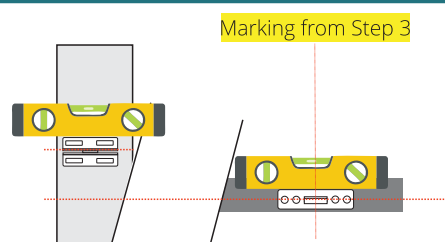

Step 5

Slide the actuator on to the post and gate brackets and fix in place using the supplied drop in pivot pin at the post bracket, for the gate bracket side use the supplied bolt and washer.

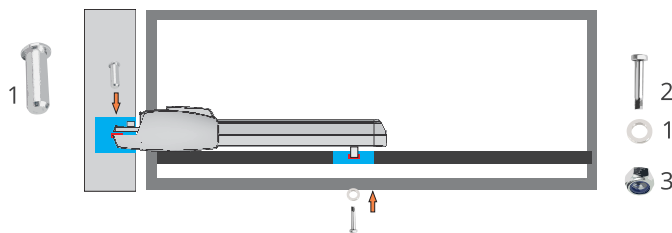

Step 6

Remove the 3 Front Cap retaining screws USING A SCREWDRIVER and pull the Front cap away from the actuator body as per illustration.

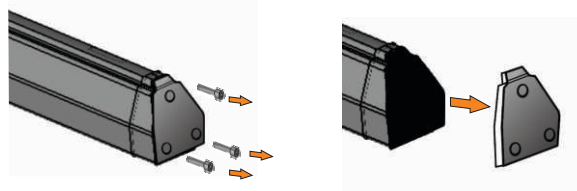

Step 7

Slide the limit switch cover away from the actuator and off the actuator by applying pressure with the palm of your hand and simultaneously pushing the cover.

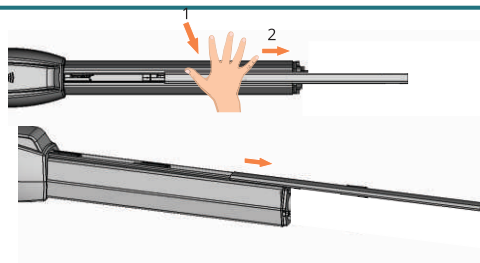

Step 8

Dis-engage the clutch by using the manual release, slowly close the gate observing the post bracket end ensure the following:

1. Gate can Open and Close without touching the gate or post
2. The post bracket requires no trimming to allow the actuator to pivot.

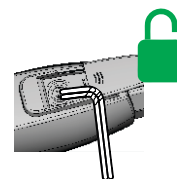

Step 9

Locate and observe the driven carrier in the inspection channel, it is black coloured and will move forwards/backwards as the gate is closed/opened. Move the gate to 45° open

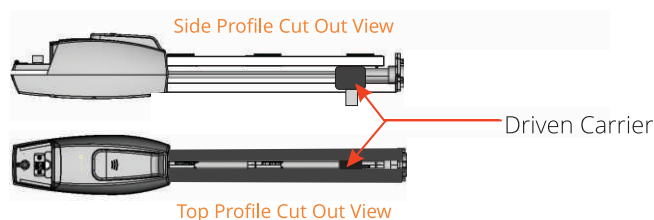
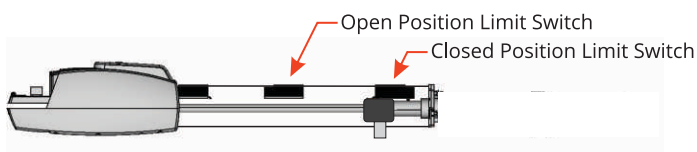

Step 10

Slowly open the gate and observe the driven carrier as it travels towards the open position limit switch, once at the open position move the limit switch slider forward/back as required til an audible mechanical click is heard from the limit switch being triggered.

If the limit switch is in the correct place but no click is heard ensure the limit switch is totally seated in the channel by pushing it down, its top should be flush with the top of the body.

Move the gate close 20°-30° and then back to open to ensure the limit switch is set correctly. Fine tune the adjustment as necessary.

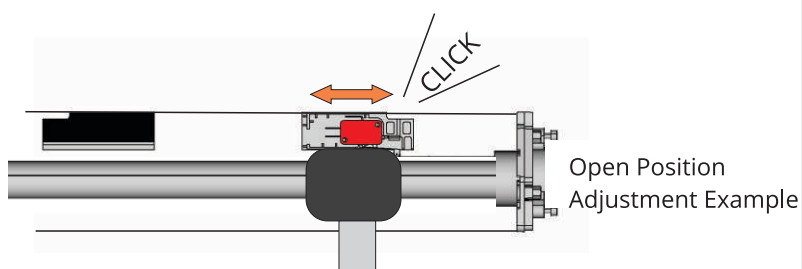

Step 11

Slowly close the gate and observe the driven limit switch striker nut as it travels towards the close position limit switch, once at the close position move the limit switch slider forward/back as required til an audible mechanical click is heard from the limit switch being triggered.

If the limit switch is in the correct place but no click is heard ensure the limit switch is totally seated in the channel by pushing it down, its top should be flush with the top of the body.

Move the gate open 20°-30° and then back to open to ensure the limit switch is set correctly. Fine tune the adjustment as necessary.

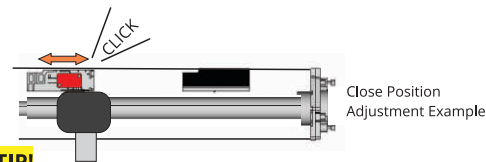

TECH TIP!

It is important to note that FOR THE BEST RESULTS the closed position limit switch should operate whilst the gate motor is pushing against the gate stop OR just after it has pushed against the gate stop. Best results are obtained by temporarily removing the gate stop and setting the limit switch point 10-20mm AFTER the gate stop allowing for a loaded gearbox (and reduced free play) when closed.

DOUBLE GATES: REPEAT ALL STEPS FOR THE SECOND MOTOR

Step 12

Follow the illustration below for the connection to the Premier 24 Swing Gate Controller paying attention to the **Motor 2 connection being the master gate** and Motor 1 Connection being the Second Motor for Double Gates.

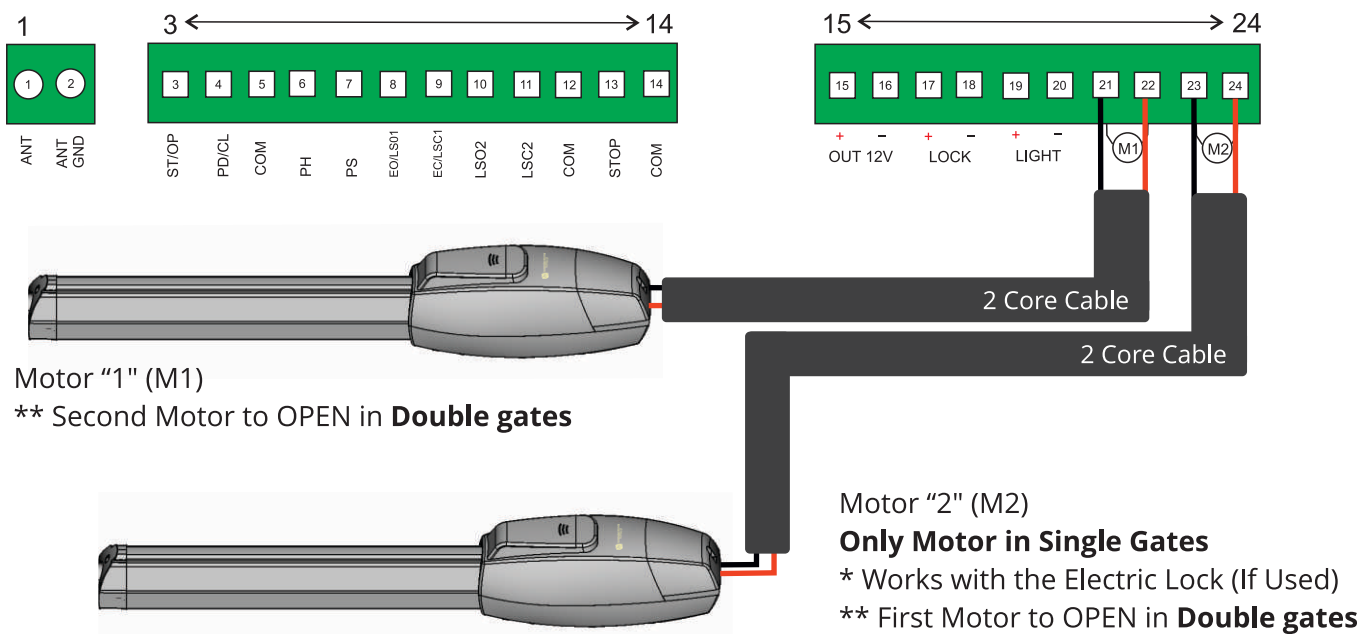

Step 13

Proceed to motor test section (Page 10)

AFTER MOTOR TEST

Re-install the limit switch cover, the small hole faces the actuator main body and will slide below the body when totally installed.

Install the front cover using a screw driver (do not use any impact drivers or electric drills)



Motor Test Mode

The purpose of motor testing is to identify the correct operating procedure before the time travel calibration. The information that can be gained from the motor test is if the motors are wired:

- Correct polarity meaning they operate in the correct direction according to the control board.
- The limit switches have been correctly set for the OPEN and CLOSED position. This test can be repeated an unlimited amount til all is set correctly.
- The correct operating sequence FOR DOUBLE GATES

O2 will open Gate 2 (M2) - The MASTER gate with the AUTOMATIC LOCK if used, First gate to open/ONLY GATE IF SINGLE GATE

C2 will close Gate 2 (M2) - Second gate to close IF double gates/ONLY GATE

O1 will open Gate 1 (M1) - Second gate (SLAVE) to open IF double gates

C1 will close Gate 1 (M1) - First gate to close IF double gates

O1/C1 is not used for single gate systems

NOTE: Safety Inputs are disabled during this stage

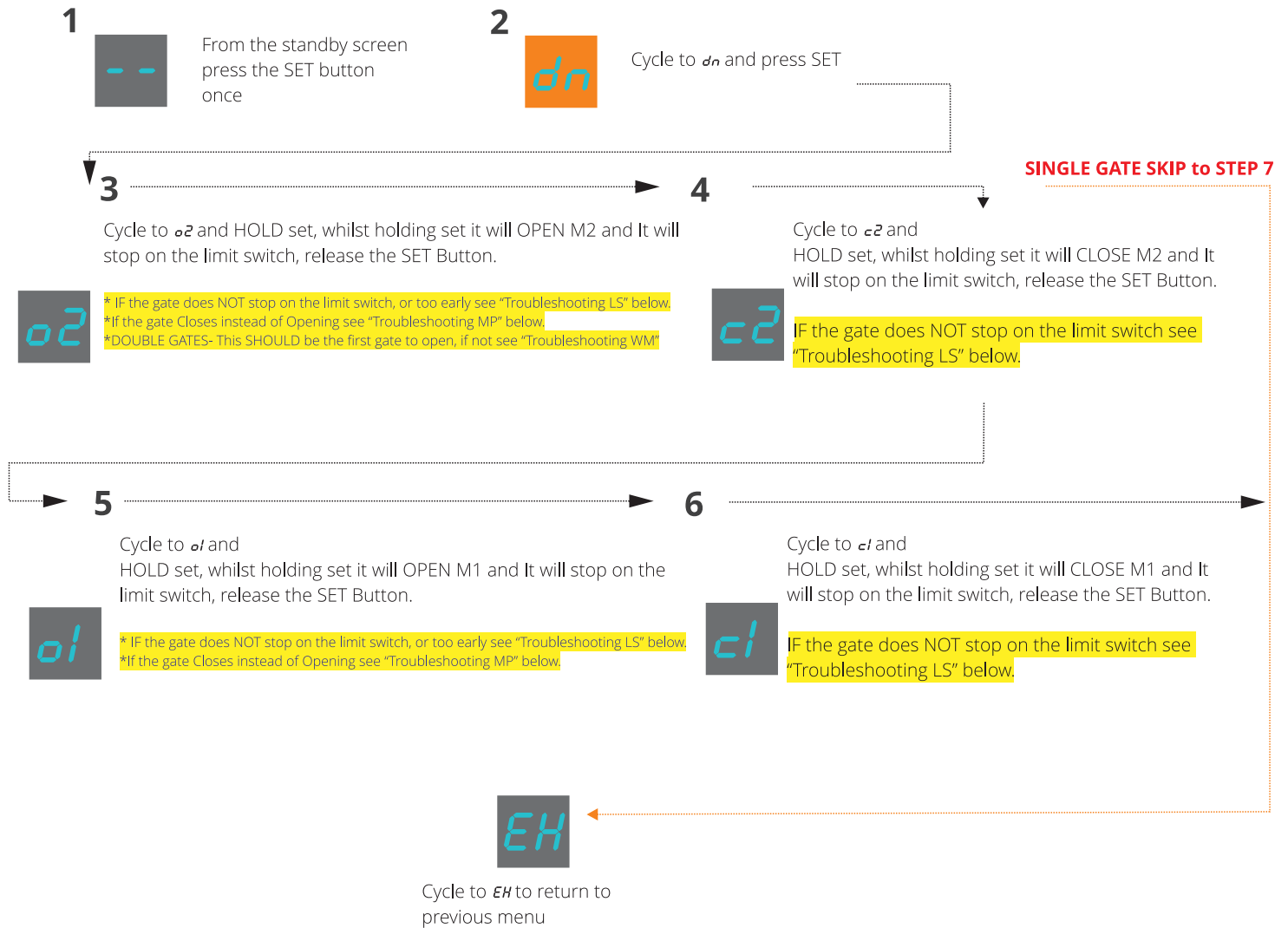

Troubleshooting MP

If the gate(s) close whilst using the open feature this is easily resolved and must be rectified prior to moving forward.

- Confirm which of the gate motor(s) is operating in the wrong direction
- Power down the controller
- Reverse the wires in the IDENTIFIED motor output terminal (this it the wires going to the gate motor)

Troubleshooting LS

If the gate(s) travel past the desired stop point OR stops too early the limit switch is misconfigured and will need to be adjusted.

- Confirm which of the limit switches is not set correctly (open limit/close limit)
- Adjust the relevant limit slider

Troubleshooting WM

In the case of double gates IF the gate that should open second is opening on O1 this must be rectified prior to moving forward.

- Power down the controller
- SWAP the wires in M1 terminal to M2 and the wires in M2 to the M1 terminal

Warranty Terms and Conditions

The product is warranted for a period of twelve months (one year) from the date of purchase, unless expressly specified as extended warranty (extension to the warranty period). The product is to be installed for its intended purpose and for normal use as outlined within the installation manual, the product warranty is exclusively for defects in manufacturing and manufacturing workmanship. It does not cover out of guidelines use, natural or other disasters, abnormal weather conditions, damage incurred in shipping or handling, damage caused by disaster such as fire, flood, wind, earthquake, lightning, excessive voltage, mechanical shock, water damage, damage caused by unauthorized attachment, alterations, modifications, or foreign objects, damage caused by peripherals (unless such peripherals were supplied by Automation Systems Australia), defects caused by failure to provide a suitable installation environment for the products, damage caused by usage of the products for purpose other than those for which it was designed, damage from improper maintenance, damage arising out of any other abuse, mishandling, and improper application of the products.

At its discretion Automation Systems Australia will require the item determined by the support staff to be returned to base in its original unmodified condition for a warranty inspection if within the warranty period. A return authorization "RA" number will be provided to be enclosed with the product in question. The warranty will not cover freight fees to base, customs fees or any labour costs at the installation site but will cover repair or replacement of the product as seen fit. Automation Systems Australia will cover the freight of the returned item to the original address if deemed as a warranty repair or replacement item. Any warranty repairs or replacements continue to carry through the remaining warranty period and do not extend or restart the period.

Under no circumstances shall Automation Systems Australia be liable for any special, incidental, or consequential damages based upon breach of warranty, breach of contract, negligence, strict liability, or any other legal theory. Such damages include, loss of profits, loss of the product or any associated equipment, cost of capital, cost of substitute or replacement equipment, facilities or services, down time, purchaser's time, the claims of third parties, including customers, and injury to property.

This warranty contains the entire warranty and shall be in lieu of any and all other warranties, whether expressed or implied (including all implied warranties of merchantability or fitness for a particular purpose). And of all other obligations or purporting to act on its behalf to modify or to change this warranty, nor to assume for it any other warranty or liability concerning this product.

Automation Systems Australia will at its option repair or replace out-of-warranty products at a determined cost which are returned to its base according to the following conditions. Anyone returning goods to Automation Systems Australia must first obtain an authorization number. Automation Systems Australia will not accept any shipment whatsoever for which prior authorization has not been obtained. Products which Automation Systems Australia determines to be repairable will be repaired and returned. A set fee which Automation Systems Australia has been predetermined and which may be revised from time to time will be charged for each unit repaired. Products which Automation Systems Australia determines not repairable will be replaced by the nearest equivalent product available at that time. The current market price for the replacement product will be charged for each replacement unit.